

Design of Magnetic Components

William P. Robbins
Dept. of Electrical and Computer Engineering
University of Minnesota

Outline

- A. Inductor/Transformer Design Relationships
- B. Magnetic Cores and Materials
- C. Power Dissipation in Copper Windings
- D. Thermal Considerations
- E. Analysis of Specific Inductor Design
- F. Inductor Design Procedures
- G. Analysis of Specific Transformer Design
- H. Eddy Currents
- J. Transformer Leakage Inductance
- K. Transformer Design Procedures

Magnetic Component Design Responsibility of Circuit Designer

- Ratings for inductors and transformers in power electronic circuits vary too much for commercial vendors to stock full range of standard parts.
- Instead only magnetic cores are available in a wide range of sizes, geometries, and materials as standard parts.
- Circuit designer must design the inductor/transformer for the particular application.
- Design consists of:
 1. Selecting appropriate core material, geometry, and size
 2. Selecting appropriate copper winding parameters: wire type, size, and number of turns.

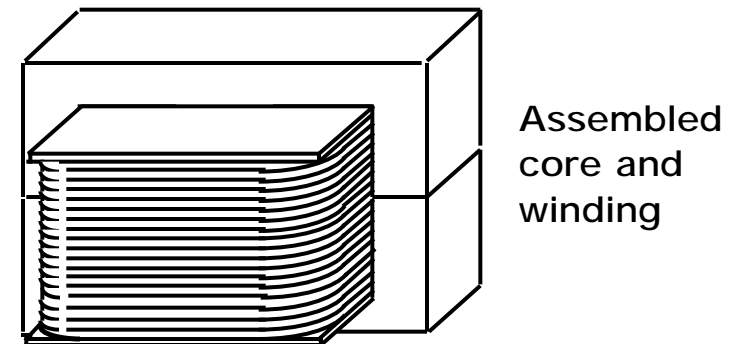
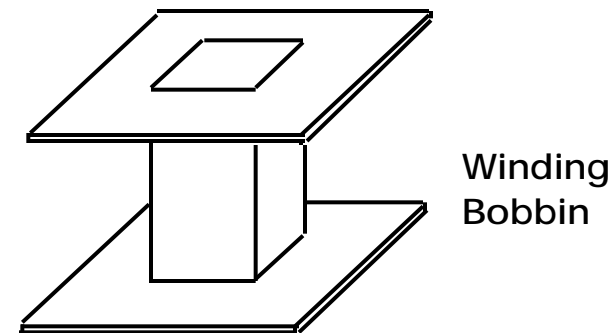
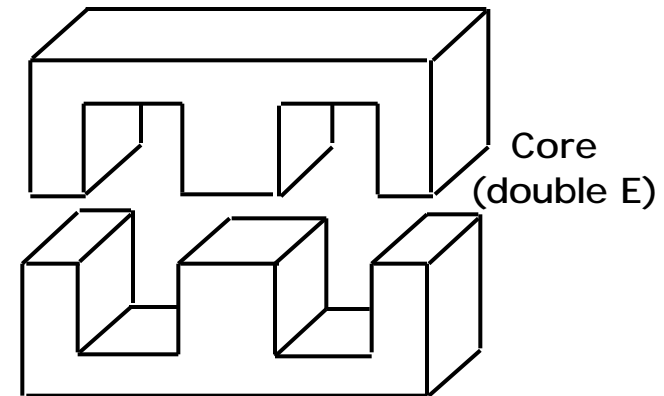

Review of Inductor Fundamentals

- Assumptions
 - No core losses or copper winding losses
 - Linearized B-H curve for core with $\mu_m \gg \mu_0$
 - $l_m \gg g$ and $A \gg g^2$
 - Magnetic circuit approximations (flux uniform over core cross-section, no fringing flux)

- Starting equations
 - $H_m l_m + H_g g = N I$ (Ampere's Law)
 - $B_m A = B_g A = \Phi$ (Continuity of flux assuming no leakage flux)
 - $\mu_m H_m = B_m$ (linearized B-H curve) ;
 - $\mu_0 H_g = B_g$

Results

- $B_s > B_m = B_g = \frac{N I}{l_m/\mu_m + g/\mu_0} = \Phi / A$
- $LI = N \Phi$; $L = \frac{A N^2}{l_m/\mu_m + g/\mu_0}$

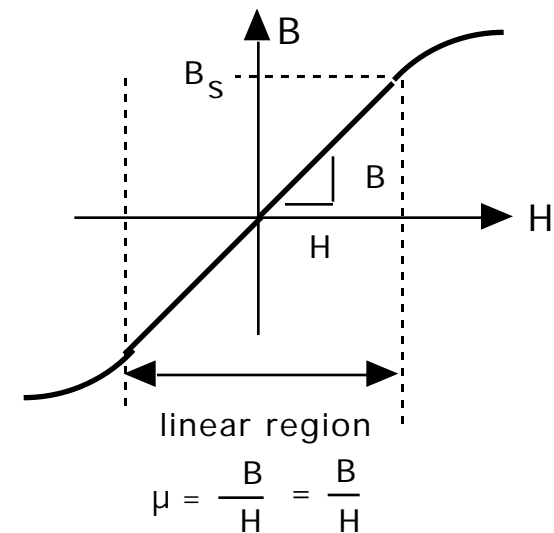
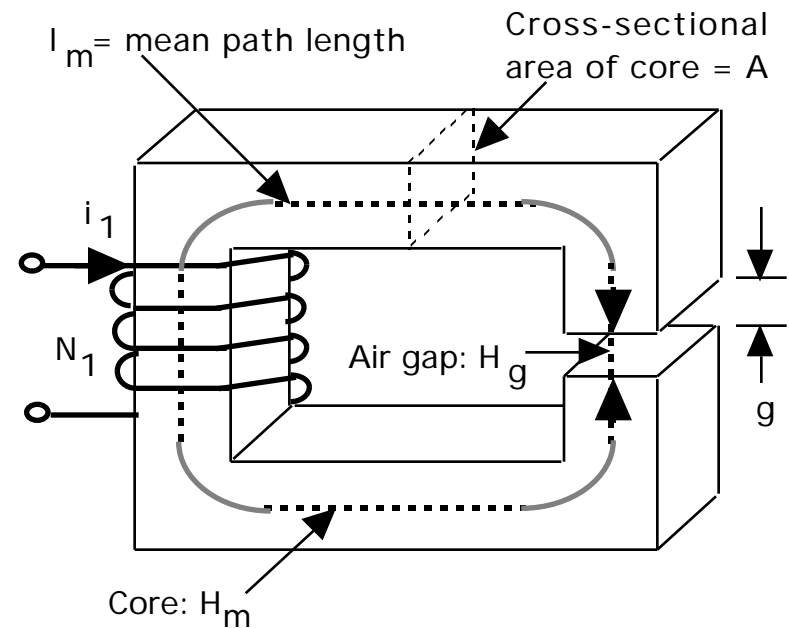

Review of Transformer Fundamentals

- Assumptions same as for inductor
- Starting equations
 - $H_1 L_m = N_1 I_1$; $H_2 L_m = N_2 I_2$
(Ampere's Law)
 - $H_m L_m = (H_1 - H_2) L_m = N_1 I_1 - N_2 I_2$
 - $\mu_m H_m = B_m$ (linearized B-H curve)

- $v_1 = N_1 \frac{d \phi_1}{dt}$; $v_2 = N_2 \frac{d \phi_2}{dt}$

(Faraday's Law)

- Net flux $\phi = \phi_1 - \phi_2 = \mu_m H_m A$

$$= \frac{\mu_m A (N_1 I_1 - N_2 I_2)}{L_m}$$

- Results assuming $\mu_m \rightarrow \infty$, i.e. ideal core or ideal transformer approximation.

- $\frac{d \phi}{dt} = 0$ and thus $N_1 I_1 = N_2 I_2$

- $\frac{d(\phi_1 - \phi_2)}{dt} = 0 = \frac{v_1}{N_1} - \frac{v_2}{N_2}$; $\frac{v_1}{N_1} = \frac{v_2}{N_2}$

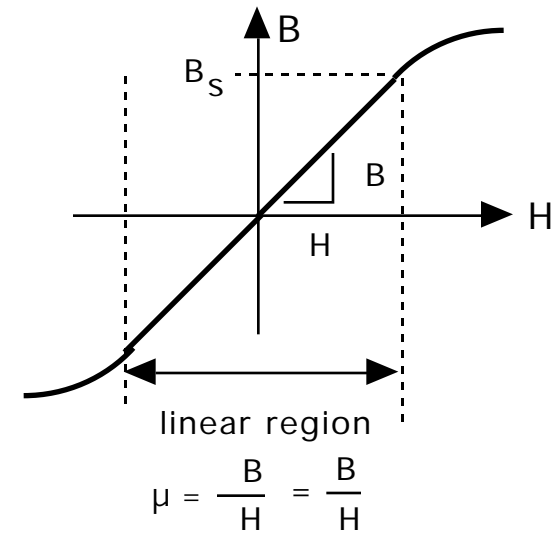
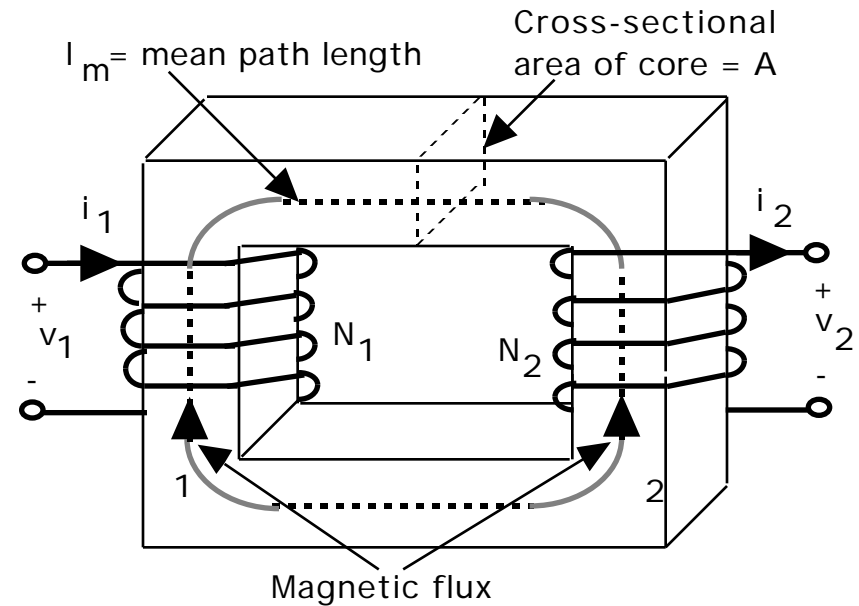

Current/Flux Density Versus Core Size

- Larger electrical ratings require larger current I and larger flux density B .
- Core losses (hysteresis, eddy currents) increase as B^2 (or greater)
- Winding (ohmic) losses increase as I^2 and are accentuated at high frequencies (skin effect, proximity effect)
- To control component temperature, surface area of component and thus size of component must be increased to reject increased heat to ambient.
 - At constant winding current density J and core flux density B , heat generation increases with volume V but surface area only increases as $V^{2/3}$.
 - Maximum J and B must be reduced as electrical ratings increase.
- Flux density B must be $< B_s$
 - Higher electrical ratings larger total flux
 larger component size
 - Flux leakage, nonuniform flux distribution complicate design

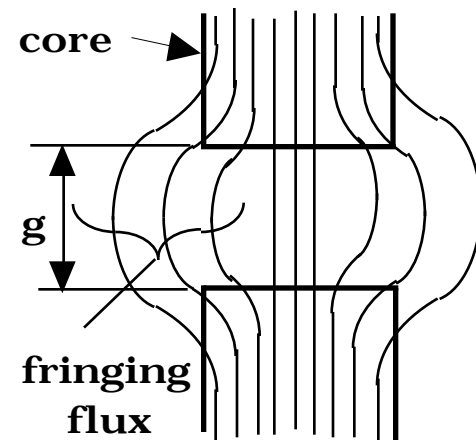
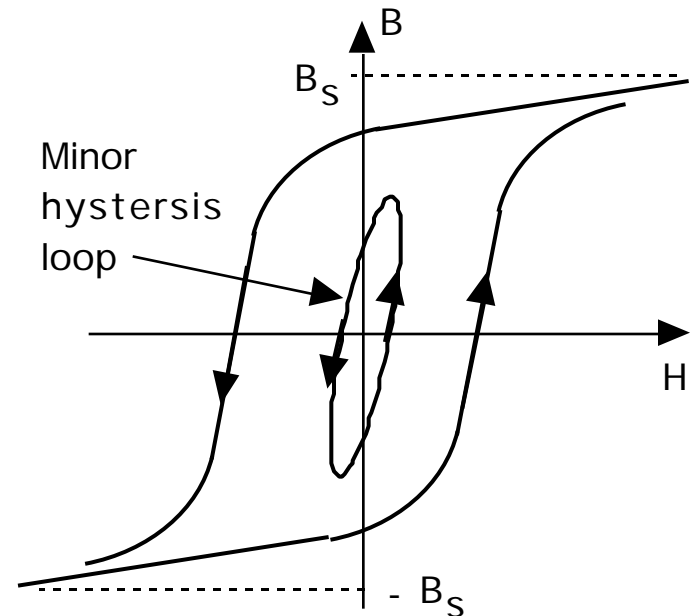

Magnetic Component Design Problem

- Challenge - conversion of component operating specs in converter circuit into component design parameters.
- Goal - simple, easy-to-use procedure that produces component design specs that result in an acceptable design having a minimum size, weight, and cost.
- Inductor electrical (e.g. converter circuit) specifications.
 - Inductance value L
 - Inductor currents rated peak current I , rated rms current I_{rms} , and rated dc current (if any) I_{dc}
 - Operating frequency f .
 - Allowable power dissipation in inductor or equivalently maximum surface temperature of the inductor T_s and maximum ambient temperature T_a .
- Transformer electrical (converter circuit) specifications.
 - Rated rms primary voltage V_{pri}
 - Rated rms primary current I_{pri}
 - Turns ratio $N_{\text{pri}}/N_{\text{sec}}$
 - Operating frequency f
 - Allowable power dissipation in transformer or equivalently maximum temperatures T_s and T_a
- Design procedure outputs.
 - Core geometry and material.
 - Core size (A_{core} , A_w)
 - Number of turns in windings.
 - Conductor type and area A_{cu} .
 - Air gap size (if needed).
- Three impediments to a simple design procedure.
 1. Dependence of J_{rms} and B on core size.
 2. How to choose a core from a wide range of materials and geometries.
 3. How to design low loss windings at high operating frequencies.
- Detailed consideration of core losses, winding losses, high frequency effects (skin and proximity effects), heat transfer mechanisms required for good design procedures.

Core Shapes and Sizes

- Magnetic cores available in a wide variety of sizes and shapes.
 - Ferrite cores available as U, E, and I shapes as well as pot cores and toroids.
 - Laminated (conducting) materials available in E, U, and I shapes as well as tape wound toroids and C-shapes.
 - Open geometries such as E-core make for easier fabrication but more stray flux and hence potentially more severe EMI problems.
 - Closed geometries such as pot cores make for more difficult fabrication but much less stray flux and hence EMI problems.
- Bobbin or coil former provided with most cores.
- Dimensions of core are optimized by the manufacturer so that for a given rating (i.e. stored magnetic energy for an inductor or V-I rating for a transformer), the volume or weight of the core plus winding is minimized or the total cost is minimized.
 - Larger ratings require larger cores and windings.
 - Optimization requires experience and computerized optimization algorithm.
 - Vendors usually are in much better position to do the optimization than the core user.

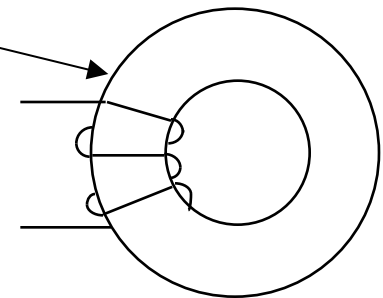
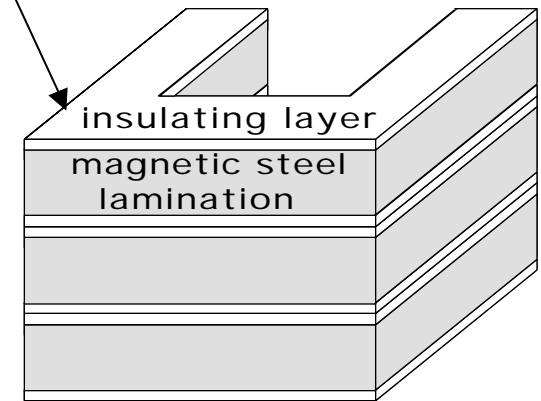
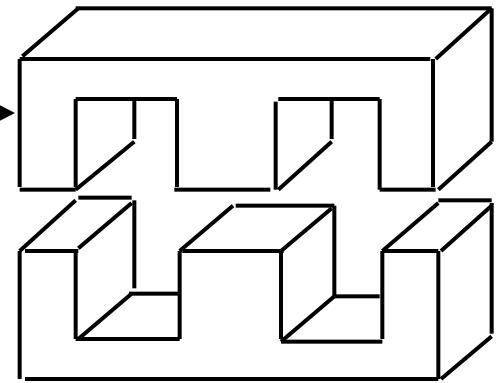

Double-E Core Example

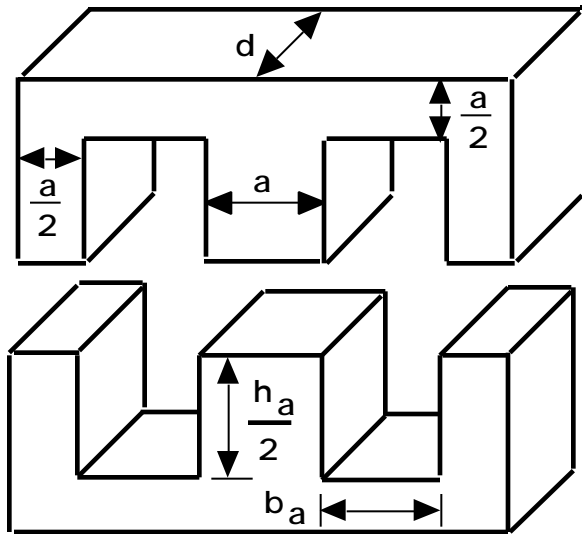

Core

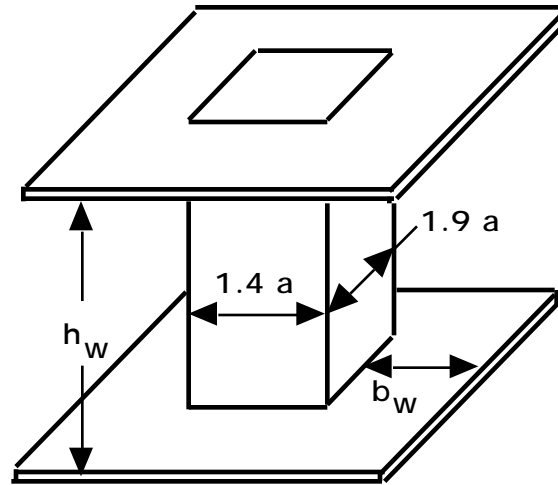

Bobbin

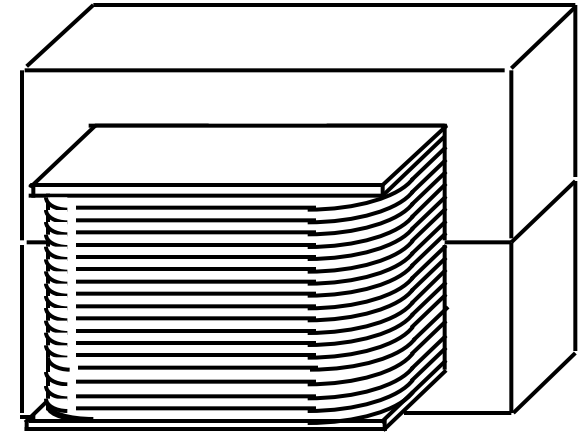

Assembled core and winding

Characteristic	Relative Size	Absolute Size for $a = 1 \text{ cm}$
Core area A_{core}	$1.5 a^2$	1.5 cm^2
Winding area A_{w}	$1.4 a^2$	1.4 cm^2
Area product $AP = A_{\text{w}}A_{\text{c}}$	$2.1 a^4$	2.1 cm^4
Core volume V_{core}	$13.5 a^3$	13.5 cm^3
Winding volume V_{w}	$12.3 a^3$	12.3 cm^3
Total surface area of assembled core and winding	$59.6 a^2$	59.6 cm^2

Types of Core Materials

- Iron-based alloys
 - Various compositions
 - Fe-Si (few percent Si)
 - Fe-Cr-Mn
 - METGLASS (Fe-B, Fe-B-Si, plus many other compositions)
 - Important properties
 - Resistivity $\rho = (10 - 100) \rho_{Cu}$
 - $B_S = 1 - 1.8 \text{ T}$ (T = tesla = 10^4 oe)
 - METGLASS materials available only as tapes of various widths and thickness.
 - Other iron alloys available as laminations of various shapes.
 - Powdered iron can be sintered into various core shapes. Powdered iron cores have larger effective resistivities.
- Ferrite cores
 - Various compositions - iron oxides, Fe-Ni-Mn oxides
 - Important properties
 - Resistivity very large (insulator) - no ohmic losses and hence skin effect problems at high frequencies.
 - $B_S = 0.3 \text{ T}$ (T = tesla = 10^4 oe)

Hysteresis Loss in Magnetic Materials

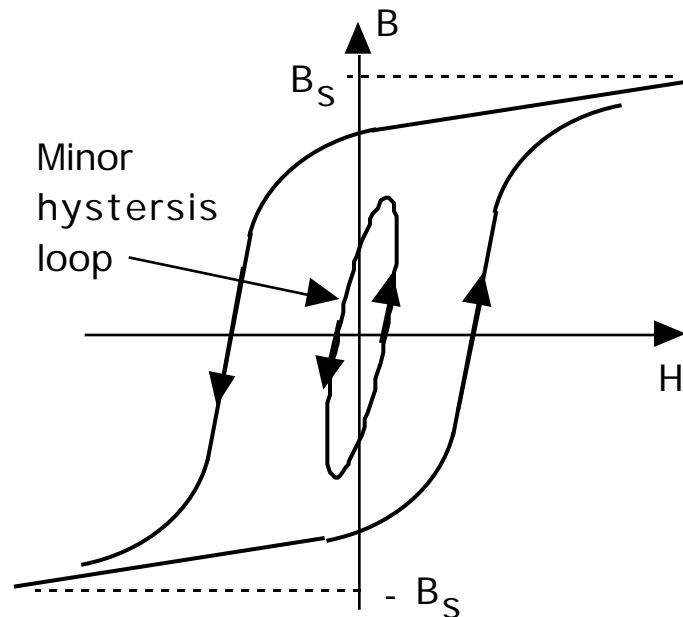

- Area encompassed by hysteresis loop equals work done on material during one cycle of applied ac magnetic field. Area times frequency equals power dissipated per unit volume.

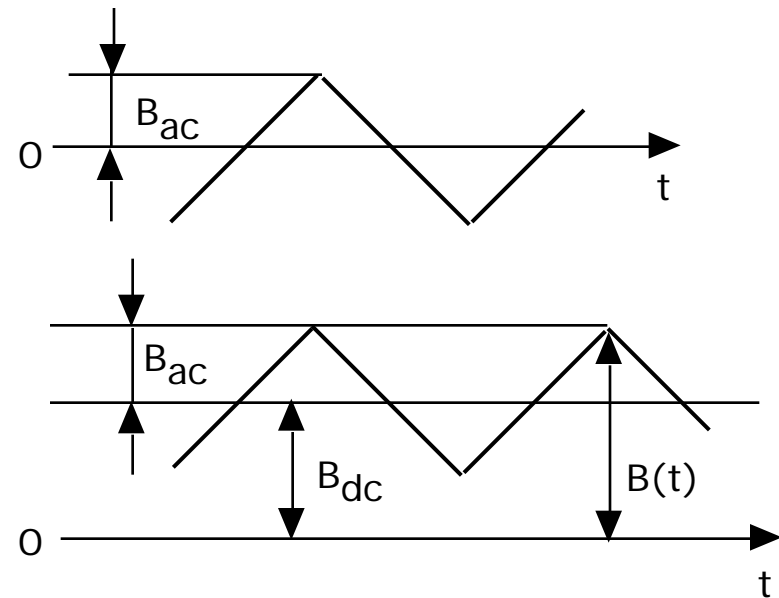

- Typical waveforms of flux density, $B(t)$ versus time, in an inductor.
- Only B_{ac} contributes to hysteresis loss.

Quantitative Description of Core Losses

- Eddy current loss plus hysteresis loss = core loss.

- Empirical equation - $P_{m,sp} = k f^a [B_{ac}]^d$

f = frequency of applied field. B_{ac} = base-to-peak value of applied ac field. k , a , and d are constants which vary from material to material

- $P_{m,sp} = 1.5 \times 10^{-6} f^{1.3} [B_{ac}]^{2.5}$
mW/cm³ for 3F3 ferrite. (f in kHz and B in mT)

- $P_{m,sp} = 3.2 \times 10^{-6} f^{1.8} [B_{ac}]^2$
mW/cm³ METGLAS 2705M (f in kHz and B in mT)

- Example: 3F3 ferrite with $f = 100$ kHz and $B_{ac} = 100$ mT, $P_{m,sp} = 60$ mW/cm³

- 3F3 core losses in graphical form.

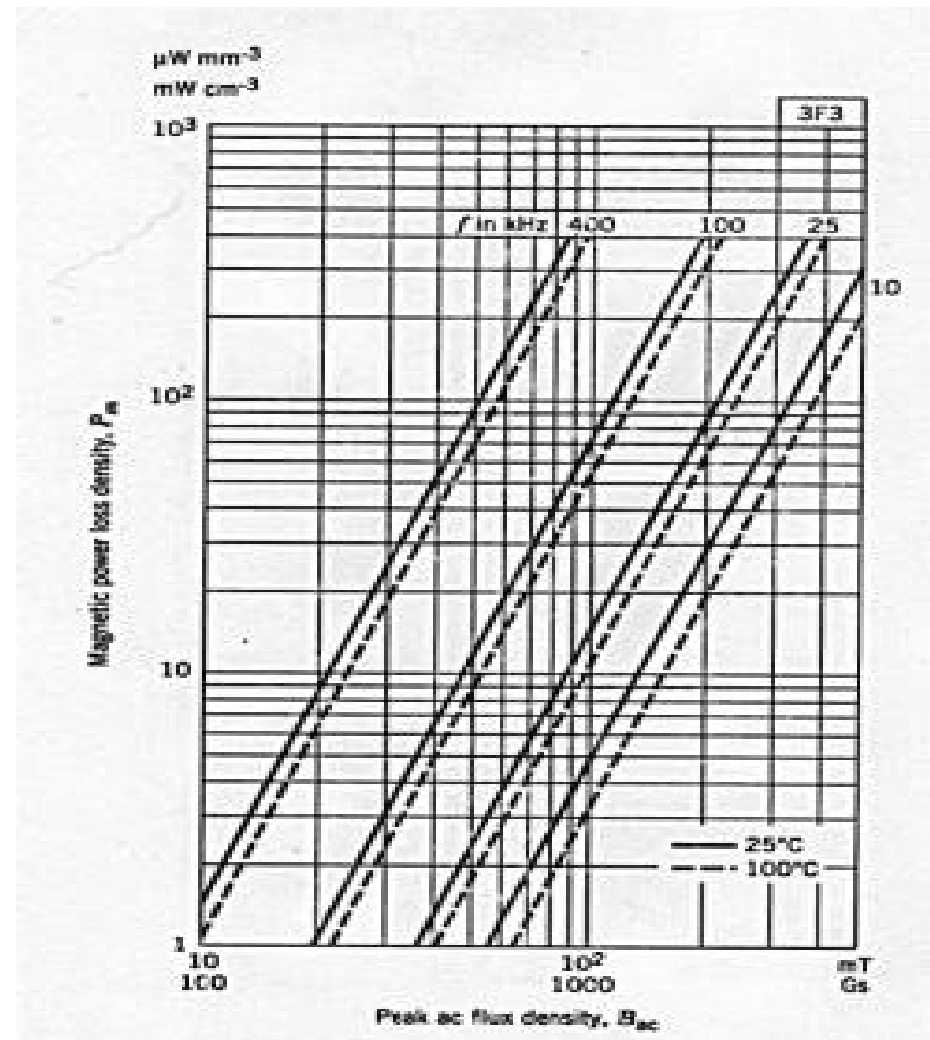

Core Material Performance Factor

- Volt-amp (V-A) rating of transformers proportional to $f B_{ac}$
- Core materials have different allowable values of B_{ac} at a specific frequency. B_{ac} limited by allowable $P_{m,sp}$.
- Most desirable material is one with largest B_{ac} .
- Choosing best material aided by defining an empirical performance factor $PF = f B_{ac}$. Plots of PF versus frequency for a specified value of $P_{m,sp}$ permit rapid selection of best material for an application.
- Plot of PF versus frequency at $P_{m,sp} = 100 \text{ mW/cm}^3$ for several different ferrites shown below.

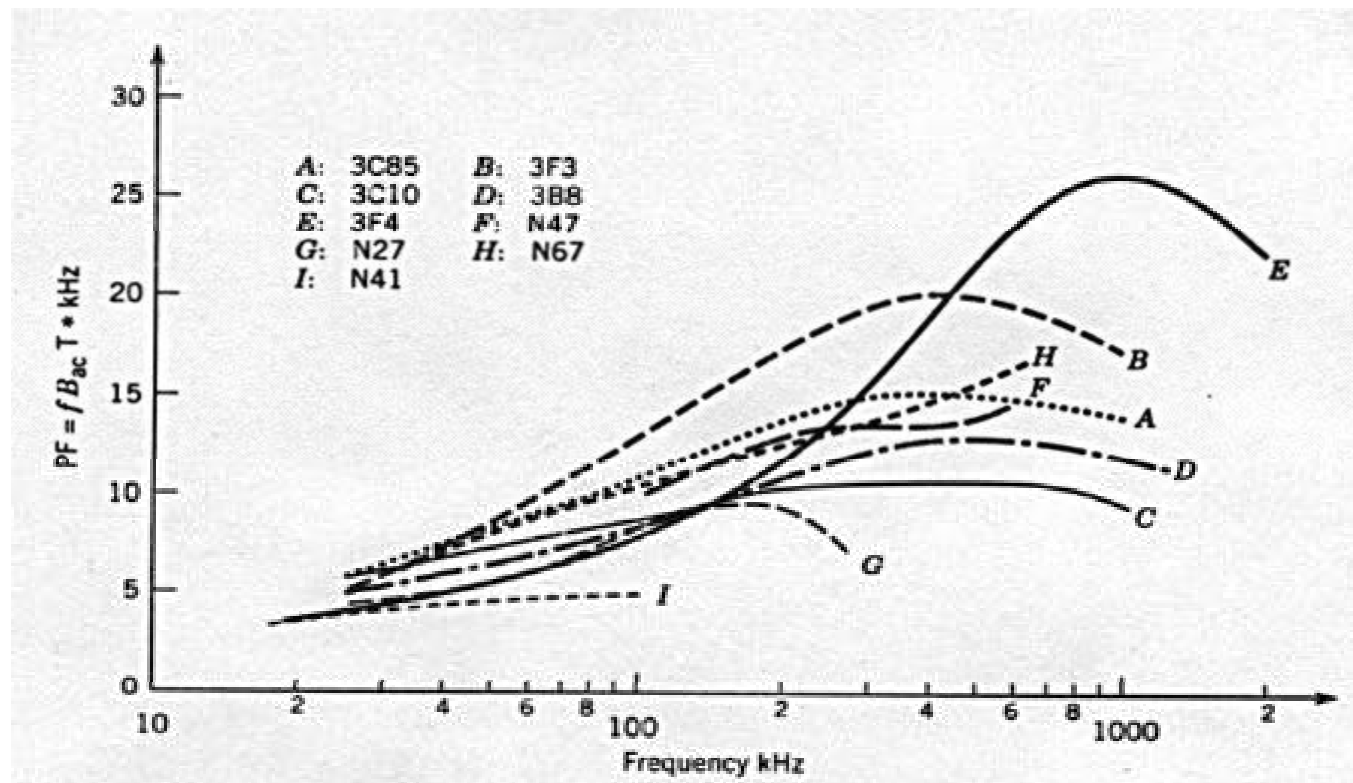

Eddy Current Losses in Magnetic Cores

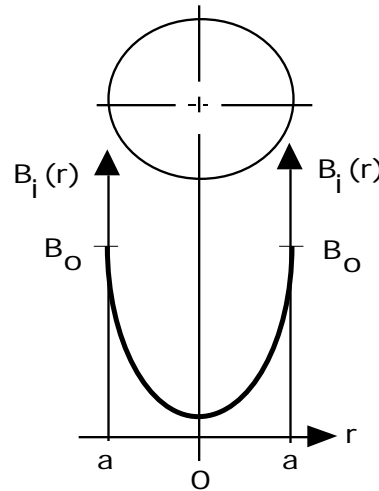
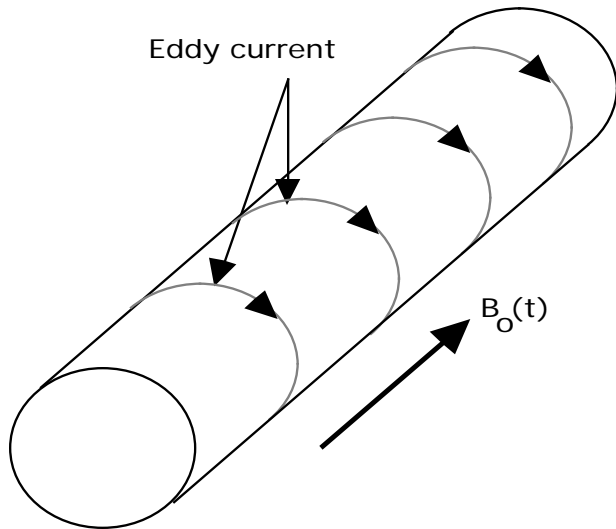

- AC magnetic fields generate eddy currents in conducting magnetic materials.
- Eddy currents dissipate power.
- Shield interior of material from magnetic field.

- $\frac{B_i(r)}{B_0} = \exp(-r/\delta)$
- $\delta = \text{skin depth} = \sqrt{\frac{2}{\omega\mu\sigma}}$
- $\omega = 2\pi f$, f = frequency
- μ = magnetic permeability ; μ_0 for magnetic materials.
- σ = conductivity of material
- Numerical example
 - $\sigma = 0.05 \text{ } \sigma_{Cu}$; $\mu = 10^3 \mu_0$
 - $f = 100 \text{ Hz}$
 - $\delta = 1 \text{ mm}$

Laminated Cores

- Cores made from conductive magnetic materials must be made of many thin laminations. Lamination thickness < skin depth.

- Stacking factor $k_{\text{stack}} = \frac{t}{t + 0.05t}$

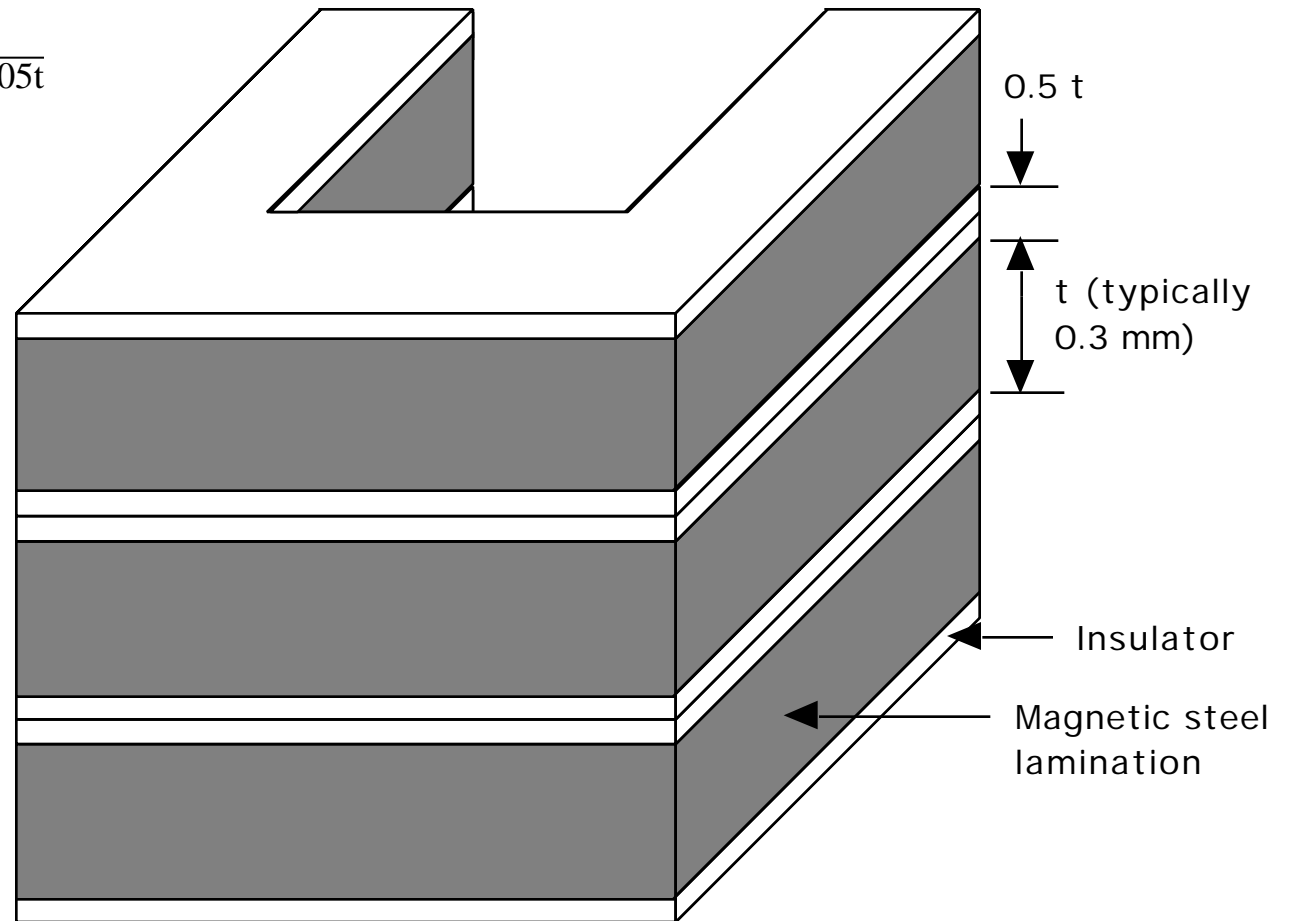

Eddy Current Losses in Laminated Cores

- Flux $\phi(t)$ intercepted by current loop of area $2xw$ given by $\phi(t) = 2xwB(t)$
- Voltage in current loop $v(t) = 2xw \frac{dB(t)}{dt}$
 $= 2wx B \cos(\omega t)$
- Current loop resistance $r = \frac{2w_{\text{core}}}{L dx}$; $w \gg d$
- Instantaneous power dissipated in thin loop

$$p(t) = \frac{[v(t)]^2}{r}$$

- Average power P_{ec} dissipated in lamination

$$\text{given by } P_{ec} = \langle p(t)dV \rangle = \frac{w L d^3 \omega^2 B^2}{24 \text{ core}}$$

- $P_{ec,sp} = \frac{P_{ec}}{V} = \frac{w L d^3 \omega^2 B^2}{24 \text{ core}} \frac{1}{dwL} = \frac{d^2 \omega^2 B^2}{24 \text{ core}}$

- Average power P_{ec} dissipated in lamination

$$\text{given by } P_{ec} = \langle p(t)dV \rangle = \frac{w L d^3 \omega^2 B^2}{24 \text{ core}}$$

- $P_{ec,sp} = \frac{P_{ec}}{V} = \frac{w L d^3 \omega^2 B^2}{24 \text{ core}} \frac{1}{dwL} = \frac{d^2 \omega^2 B^2}{24 \text{ core}}$

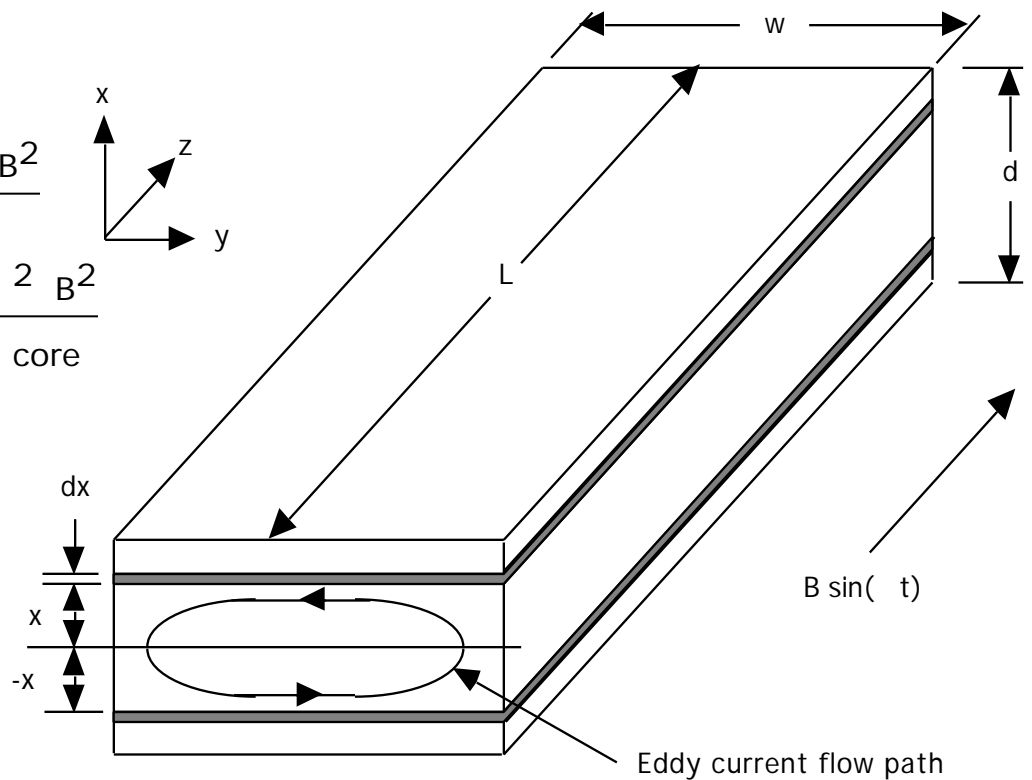

Power Dissipation in Windings

- Average power per unit volume of copper dissipated in copper winding = $P_{cu,sp} = \rho_{cu} (J_{rms})^2$ where $J_{rms} = I_{rms}/A_{cu}$ and ρ_{cu} = copper resistivity.
- Average power dissipated per unit volume of winding = $P_{w,sp} = k_{cu} \rho_{cu} (J_{rms})^2$; $V_{cu} = k_{cu} V_w$ where V_{cu} = total volume of copper in the winding and V_w = total volume of the winding.

- Copper fill factor $k_{cu} = \frac{N A_{cu}}{A_w} < 1$

- N = number of turns; A_{cu} = cross-sectional area of copper conductor from which winding is made; $A_w = b_w l_w$ = area of winding window.
- $k_{cu} = 0.3$ for Leitz wire; $k_{cu} = 0.6$ for round conductors; $k_{cu} = 0.7-0.8$ for rectangular conductors.

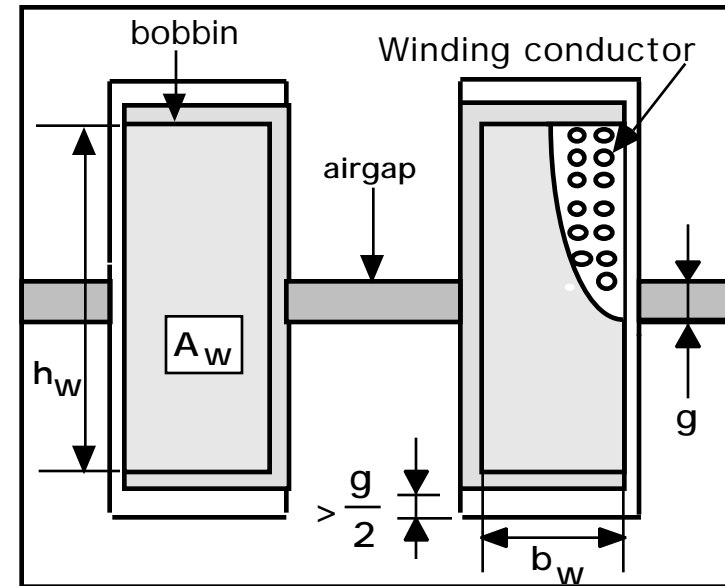

Double-E core example

- $k_{cu} < 1$ because:
 - Insulation on wire to avoid shorting out adjacent turns in winding.
 - Geometric restrictions. (e.g. tight-packed circles cannot cover 100% of a square area.)

Eddy Currents Increase Winding Losses

- AC currents in conductors generate ac magnetic fields which in turn generate eddy currents that cause a nonuniform current density in the conductor. Effective resistance of conductor increased over dc value.

- $P_{w,sp} > k_{cu} \rho_{cu} (J_{rms})^2$ if conductor dimensions greater than a skin depth.

- $\frac{J(r)}{J_0} = \exp(-r/a)$

- $a = \text{skin depth} = \sqrt{\frac{2}{\mu f}}$
- $a = 2 \sqrt{f}$, f = frequency of ac current
- μ = magnetic permeability of conductor;
 $\mu = \mu_0$ for nonmagnetic conductors.
- ρ_{cu} = conductivity of conductor material.

- Numerical example using copper at 100 °C

Frequency	50 Hz	5 kHz	20 kHz	500 kHz
Skin Depth	10.6 mm	1.06 mm	0.53 mm	0.106 mm

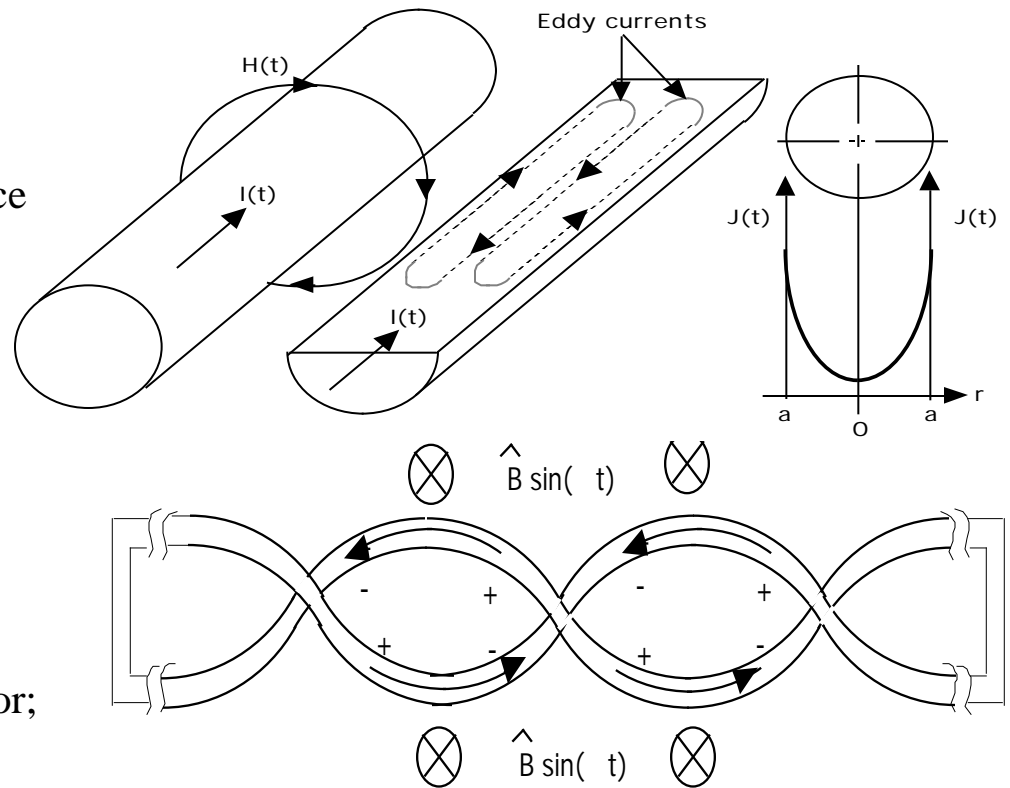

- Minimize eddy currents using Leitz wire bundle. Each conductor in bundle has a diameter less than a skin depth.
- Twisting of paralleled wires causes effects of intercepted flux to be canceled out between adjacent twists of the conductors. Hence little if any eddy currents.

Proximity Effect Further Increases Winding Losses

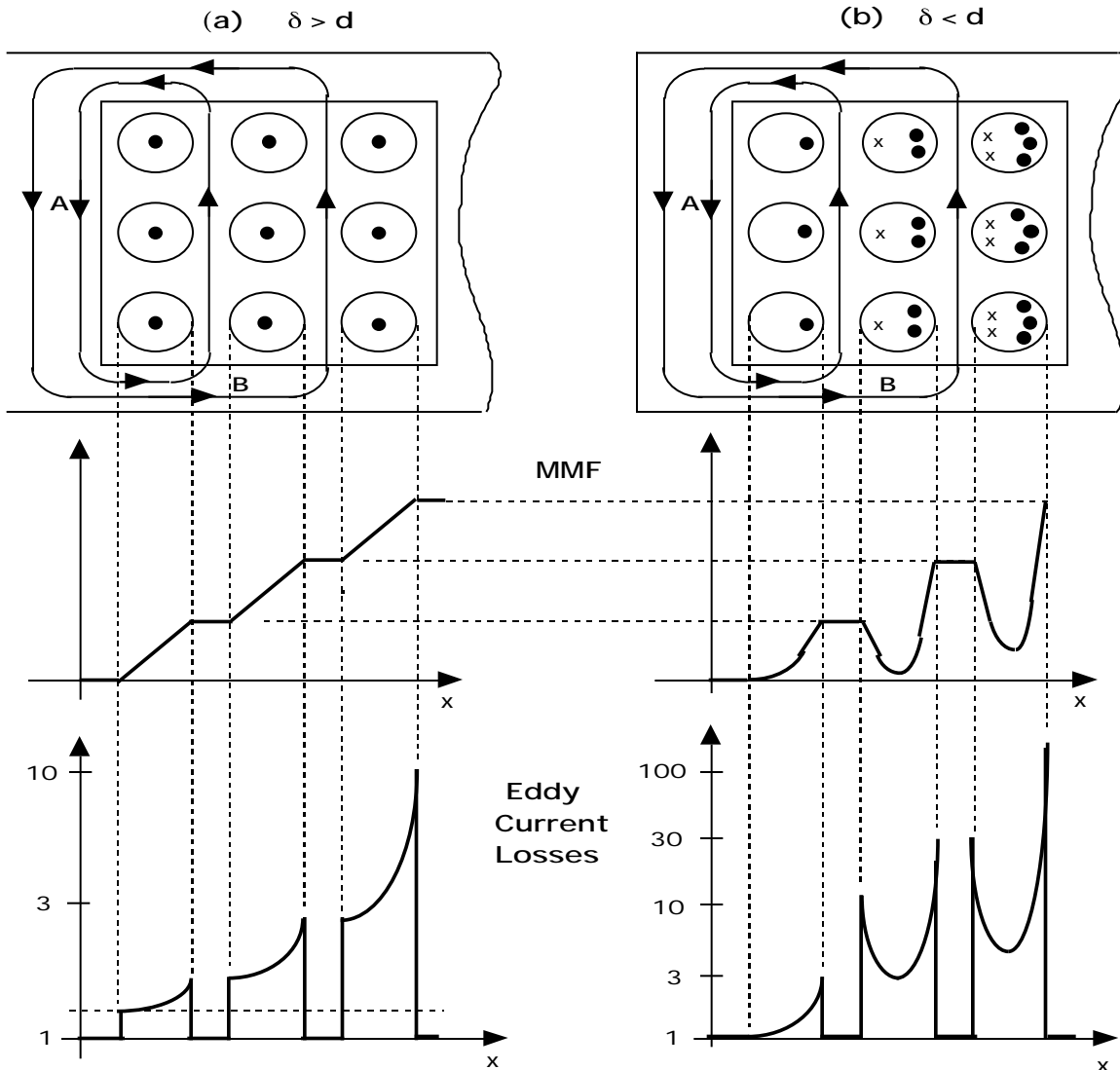

- Proximity effect - losses due to eddy current generated by the magnetic field experienced by a particular conductor section but generated by the current flowing in the rest of the winding.
- Design methods for minimizing proximity effect losses discussed later.

Minimum Winding Loss

- $P_w = P_{dc} + P_{ec}$; P_{ec} = eddy current loss.

Optimum conductor size

- $P_w = \{ R_{dc} + R_{ec} \} [I_{rms}]^2 = R_{ac} [I_{rms}]^2$

- $R_{ac} = F_R R_{dc} = [1 + R_{ec}/R_{dc}] R_{dc}$

- Minimum winding loss at optimum conductor size.

- $P_w = 1.5 P_{dc}$

- $P_{ec} = 0.5 P_{dc}$

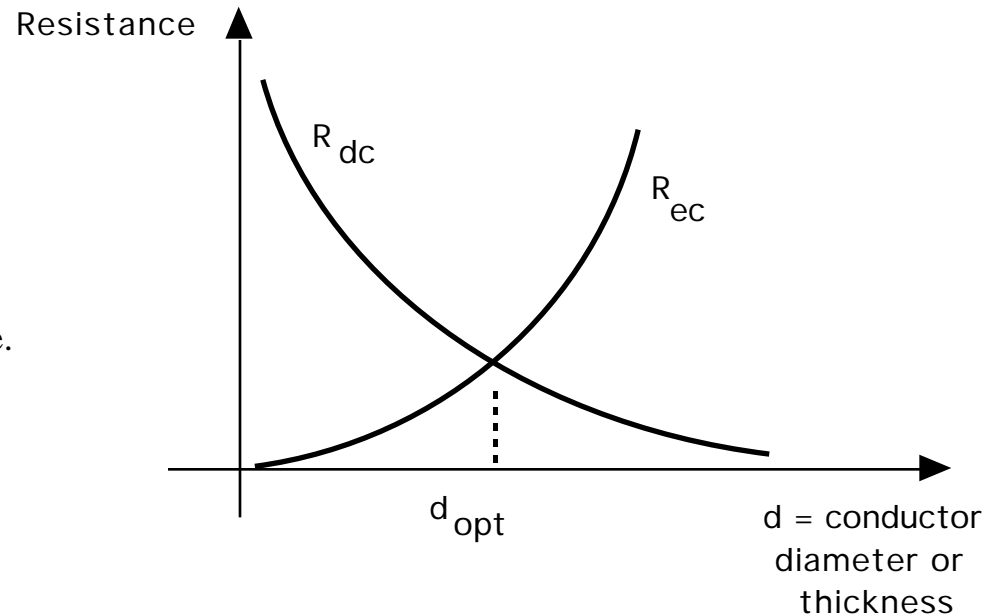

- High frequencies require small conductor sizes minimize loss.

- P_{dc} kept small by putting many small-size conductors in parallel using Litz wire or thin but wide foil conductors.

Thermal Considerations in Magnetic Components

- Losses (winding and core) raise core temperature. Common design practice to limit maximum interior temperature to 100-125 °C.
- Core losses (at constant flux density) increase with temperature increases above 100 °C
- Saturation flux density B_s decreases with temp. Increases
- Nearby components such as power semiconductor devices, integrated circuits, capacitors have similar limits.
- Temperature limitations in copper windings
 - Copper resistivity increases with temperature increases. Thus losses, at constant current density increase with temperature.
 - Reliability of insulating materials degrade with temperature increases.
- Surface temperature of component nearly equal to interior temperature. Minimal temperature gradient between interior and exterior surface.
 - Power dissipated uniformly in component volume.
 - Large cross-sectional area and short path lengths to surface of components.
 - Core and winding materials have large thermal conductivity.
- Thermal resistance (surface to ambient) of magnetic component determines its temperature.
- $$P_{sp} = \frac{T_s - T_a}{R_{sa}(V_w + V_c)} ; R_{sa} = \frac{h}{A_s}$$
 - h = convective heat transfer coefficient = $10 \text{ }^\circ\text{C}\cdot\text{m}^2/\text{W}$
 - A_s = surface area of inductor (core + winding). Estimate using core dimensions and simple geometric considerations.
 - Uncertain accuracy in h and other heat transfer parameters do not justify more accurate thermal modeling of inductor.

Scaling of Core Flux Density and Winding Current Density

- Power per unit volume, P_{sp} , dissipated in magnetic component is $P_{sp} = k_1/a$; $k_1 = \text{constant}$ and $a = \text{core scaling dimension}$.
- $P_{w,sp} V_w + P_{m,sp} V_m = \frac{T_s - T_a}{R_{sa}}$:
 $T_a = \text{ambient temperature}$ and $R_{sa} = \text{surface-to-ambient thermal resistance of component}$.
- For optimal design $P_{w,sp} = P_{c,sp} = P_{sp}$:
Hence $P_{sp} = \frac{T_s - T_a}{R_{sa}(V_w + V_c)}$
- R_{sa} proportional to a^2 and $(V_w + V_c)$ proportional to a^3
- $J_{rms} = \sqrt{\frac{P_{sp}}{k_{cu} r_{cu}}} = k_2 \frac{1}{\sqrt{k_{cu} a}}$; $k_2 = \text{constant}$
- $P_{m,sp} = P_{sp} = k f^b [B_{ac}]^d$; Hence
 $B_{ac} = \sqrt[d]{\frac{P_{sp}}{k f^b}} = \frac{k_3}{\sqrt[d]{f^b a}}$ where $k_3 = \text{constant}$
- Plots of J_{rms} , B_{ac} , and P_{sp} versus core size (scale factor a) for a specific core material, geometry, frequency, and $T_s - T_a$ value very useful for picking appropriate core size and winding conductor size.

Example of Power Density and Current Density Scaling

Assumptions

1. Double-E core made from 3F3 ferrite
2. $T_s = 100\text{ }^\circ\text{C}$ and $T_a = 40\text{ }^\circ\text{C}$.
3. Winding made with Leitz wire - $k_{cu} = 0.3$

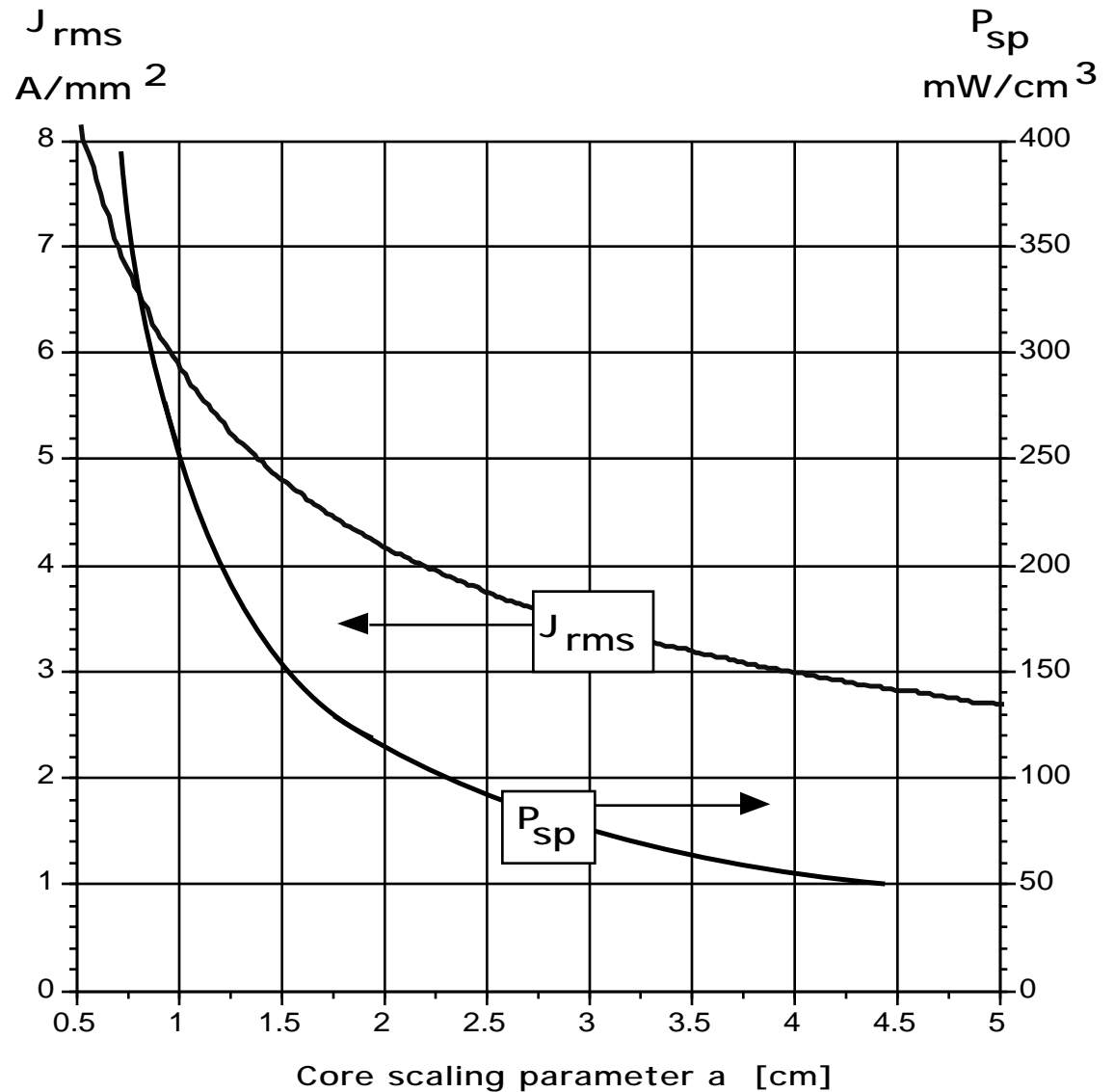

Analysis of a Specific Inductor Design

- Inductor specifications
 - Maximum current = 4 ams rms at 100 kHz
 - Double-E core with $a = 1$ cm using 3F3 ferrite.
 - Distributed air-gap with four gaps, two in series in each leg; total gap length $g = 3$ mm.
 - Winding - 66 turns of Litz wire with $A_{cu} = 0.64$ mm²
 - Inductor surface black with emissivity = 0.9
 - $T_{a,max} = 40$ °C
- Find; inductance L , $T_{s,max}$; effect of a 25% overcurrent on T_s
- Power dissipation in winding, $P_w = V_w k_{cu} c_{cu} (J_{rms})^2 = 3.2$ Watts
 - $V_w = 12.3$ cm³ (table of core characteristics)
 - $k_{cu} = 0.3$ (Litz wire)
 - c_{cu} at 100 °C (approx. max. T_s) = 2.2×10^{-8} ohm-m
 - $J_{rms} = 4 / (.64) = 6.25$ A/mm²
- Power dissipation in 3F3 ferrite core,

$$P_{core} = V_c 1.5 \times 10^{-6} f^{1.3} (B_{ac})^{2.5} = 3.3$$
 W
 - $B_{ac} = \frac{A_g \mu_0 N \sqrt{2} I_{rms}}{A_c g} = 0.18$ mT; assumes $H_g \gg H_{core}$
 - $A_g = (a + g)(d + g) = 1.71$ cm² ; $g = 3\text{mm}/4 = .075$ mm
 - $A_c = 1.5$ cm² (table of core characteristics)
 - $V_c = 13.5$ cm³ (table of core characteristics)
 - $f = 100$ kHz

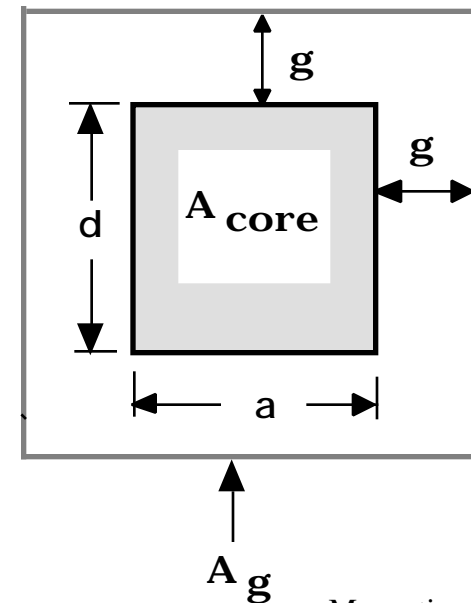
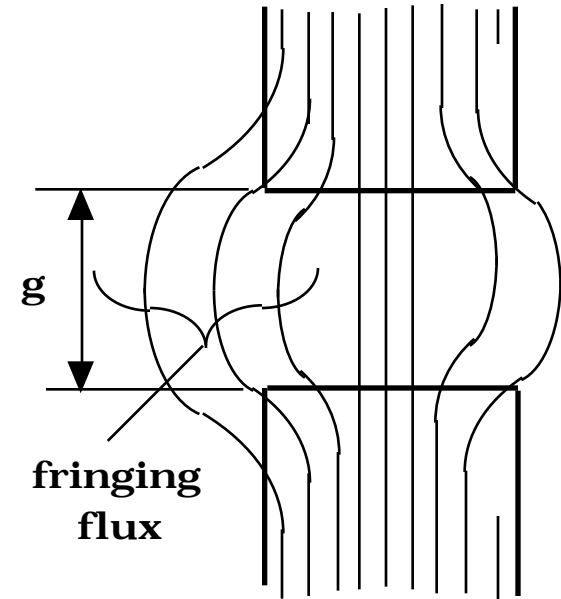

Analysis of a Specific Inductor Design (cont.)

- $L = \frac{N}{I} = 310 \mu\text{H}$
 - $= B_{ac} A_c = (0.18 \text{ T})(1.5 \times 10^{-4} \text{ m}^2) = 2.6 \times 10^{-5} \text{ Wb}$

- Surface temperature $T_s = T_a + R_{sa} (P_w + P_{core}) = 104 \text{ }^\circ\text{C}$
 - $R_{sa} = R_{rad} \parallel R_{conv} = 9.8 \text{ }^\circ\text{C/W}$
 - $R_{rad} = \frac{60}{(5.1)(0.006) \left[\frac{373^4}{100} - \frac{313^4}{100} \right]} = 20.1 \text{ }^\circ\text{C/W}$
 - $R_{conv} = \frac{1}{(1.34)(0.006)} \sqrt[4]{\frac{0.035}{60}} = 19.3 \text{ }^\circ\text{C/W}$

- Overcurrent of 25% ($I = 5 \text{ amp rms}$) makes $T_s = 146 \text{ }^\circ\text{C}$
 - $P_w = (3.2 \text{ W})(1.25)^2 = 5 \text{ W}$; $P_{core} = (3.3 \text{ W})(1.25)^{2.5} = 5.8 \text{ W}$
 - $T_s = (9.8 \text{ }^\circ\text{C/W})(10.8 \text{ W}) + 40 \text{ }^\circ\text{C} = 146 \text{ }^\circ\text{C}$

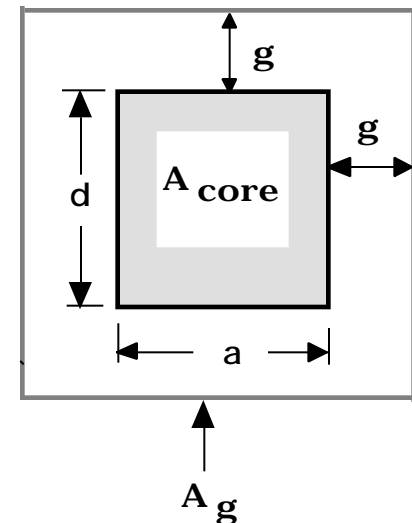
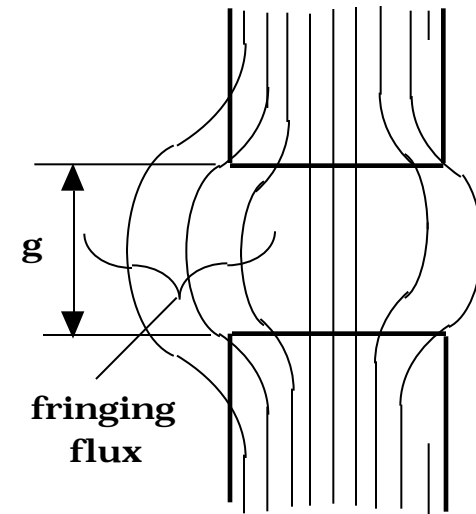

Stored Energy Relation - Basis of Inductor Design

- Input specifications for inductor design
 - Inductance value L .
 - Rated peak current I
 - Rated rms current I_{rms} .
 - Rated dc current (if any) I_{dc} .
 - Operating frequency f .
 - Maximum inductor surface temperature T_s and maximum ambient temperature T_a .
- Design consists of the following:
 - Selection of core geometric shape and size
 - Core material
 - Winding conductor geometric shape and size
 - Number of turns in winding
- Design procedure starting point - stored energy relation
 - $[L I] I_{rms} = [N] I_{rms}$
 - $N = \frac{k_{cu} A_w}{A_{cu}}$
 - $= B A_{core} ; I_{rms} = J_{rms} A_{cu}$
 - $L I I_{rms} = k_{cu} J_{rms} B A_w A_{core}$
 - Equation relates input specifications (left-hand side) to needed core and winding parameters (right-hand side)
 - A good design procedure will consists of a systematic, single-pass method of selecting k_{cu} , J_{rms} , B , A_w , and A_{core} .

Goal: Minimize inductor size, weight, and cost.

Core Database - Basic Inductor Design Tool

- Interactive core database (spreadsheet-based) key to a single pass inductor design procedure.
 - User enters input specifications from converter design requirements. Type of conductor for windings (round wire, Leitz wire, or rectangular wire or foil) must be made so that copper fill factor k_{cu} is known.
 - Spreadsheet calculates capability of all cores in database and displays smallest size core of each type that meets stored energy specification.
 - Also can be designed to calculate (and display as desired) design output parameters including J_{rms} , B , A_{cu} , N , and air-gap length.
 - Multiple iterations of core material and winding conductor choices can be quickly done to aid in selection of most appropriate inductor design.

- Information on all core types, sizes, and materials must be stored on spreadsheet. Info includes dimensions, A_w , A_{core} , surface area of assembled inductor, and loss data for all materials of interest.

- Pre-stored information combined with user inputs to produce performance data for each core in spreadsheet. Sample of partial output shown below.

Core No.	Material	AP = $A_w A_{core}$	R T=60 °C	P _{sp} @ T=60 °C	J _{rms} @ T=60 °C & P _{sp}	B _{ac} @ T=60 °C & 100 kHz	$k_{cu} J_{rms} \hat{B}$ • $A_w A_{core}$
• 8 •	• 3F3 •	• 2.1 cm ⁴ •	• 9.8 °C/W •	• 237 mW/cm ³ •	• $3.3/\sqrt{k_{cu}}$ •	• 170 mT •	• $.0125\sqrt{k_{cu}}$ •

Details of Interactive Inductor Core Database Calculations

- User inputs: $L, I, I_{rms}, I_{dc}, f, T_s, T_a,$ and k_{cu}
- Stored information (static, independent of converter requirements)
 - Core dimensions, $A_w, A_{core}, V_c, V_w,$ surface area, mean turn length, mean magnetic path length, etc.
 - Quantitative core loss formulas for all materials of interest including approximate temperature dependence.
- Calculation of core capabilities (stored energy value)
 1. Compute converter-required stored energy value: $L I I_{rms}$.
 2. Compute allowable specific power dissipation $P_{sp} = [T_s - T_a] / \{ R_{sa} [V_c + V_w] \}$. $R_{sa} = h/A_s$ or calculated interactively using input temperatures and formulas for convective and radiative heat transfer from Heat Sink chapter.
 3. Compute allowable flux density $P_{sp} = k f^b [B_{ac}]^d$ and current density $P_{sp} = k_{cu} J_{rms}^2$.
 4. Compute core capabilities $k_{cu} A_w A_{core} B J_{rms}$
- Calculation of inductor design parameters.
 1. Area of winding conductor $A_{cu} = I / J_{rms}$.
 2. Calculate skin depth in winding. If $A_{cu} > \delta^2$ at the operating frequency, then single round conductor cannot be used for winding.
 - Construct winding using Leitz wire, thin foils, or paralleled small dia. () round wires.

Details of Interactive Core Database Calculations (cont.)

3. Calculate number turns of N in winding: $N = k_{cu} A_w / A_{cu}$.
4. Calculate air-gap length L_g . Air-gap length determined on basis that when inductor current equals peak value I, flux density equals peak value B.
 - Formulas for air-gap length different for different core types. Example for double-E core given in next slide.
5. Calculate maximum inductance L_{max} that core can support. $L_{max} = N A_{core} B_{peak} / I_{peak}$.

If $L_{max} >$ required L value, reduce L_{max} by removing winding turns.

 - Save on copper costs, weight, and volume.
 - P_w can be kept constant by increasing $P_{w,sp}$
 - Keep flux density B_{peak} constant by adjusting gap length L_g .
6. Alternative L_{max} reduction procedure, increasing the value of L_g , keeping everything else constant, is a poor approach. Would not reduce copper weight and volume and thus achieve cost savings. Full capability of core would not be utilized.

Setting Double-E Core Air-gap Length

- Set total airgap length L_g so that B_{peak} generated at the peak current I_{peak} .
- $L_g = N_g g$; N_g = number of distributed gaps each of length g .
Distributed gaps used to minimize amount of flux fringing into winding and thus causing additional eddy current losses.
- $R_m = \frac{N I_{peak}}{A_c B_{peak}} = R_{m,core} + R_{m,gap}$ $R_{m,gap} = \frac{L_g}{\mu_0 A_g}$
- $L_g = \frac{N I_{peak} \mu_0 A_g}{A_c B_{peak}}$
- For a double-E core, $A_g = (a + \frac{L_g}{N_g}) (d + \frac{L_g}{N_g})$
- $A_g = ad + (a + d) \frac{L_g}{N_g}$; $\frac{L_g}{N_g} \ll a$
- Insertion of expression for $A_g(L_g)$ into expression for $L_g(A_g)$ and solving for L_g yields

$$L_g = \frac{a}{\frac{B_{peak} A_c}{d \mu_0 N I_{peak}} - \frac{a + d}{d N_g}}$$

- Above expression for L_g only valid for double-E core, but similar expressions can be developed for other core shapes.

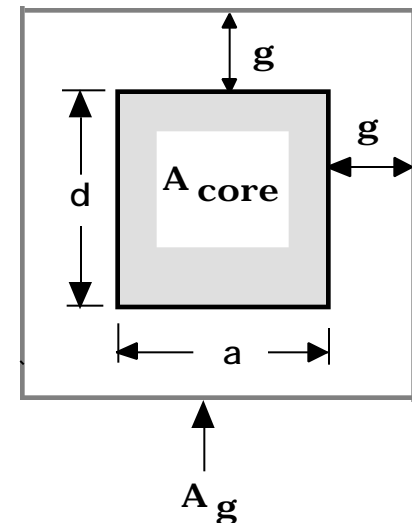
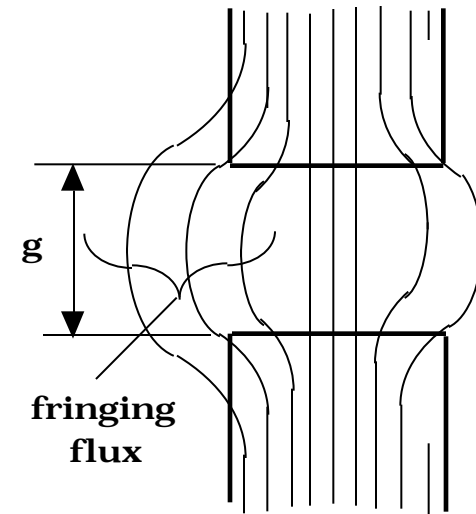

Single Pass Inductor Design Procedure

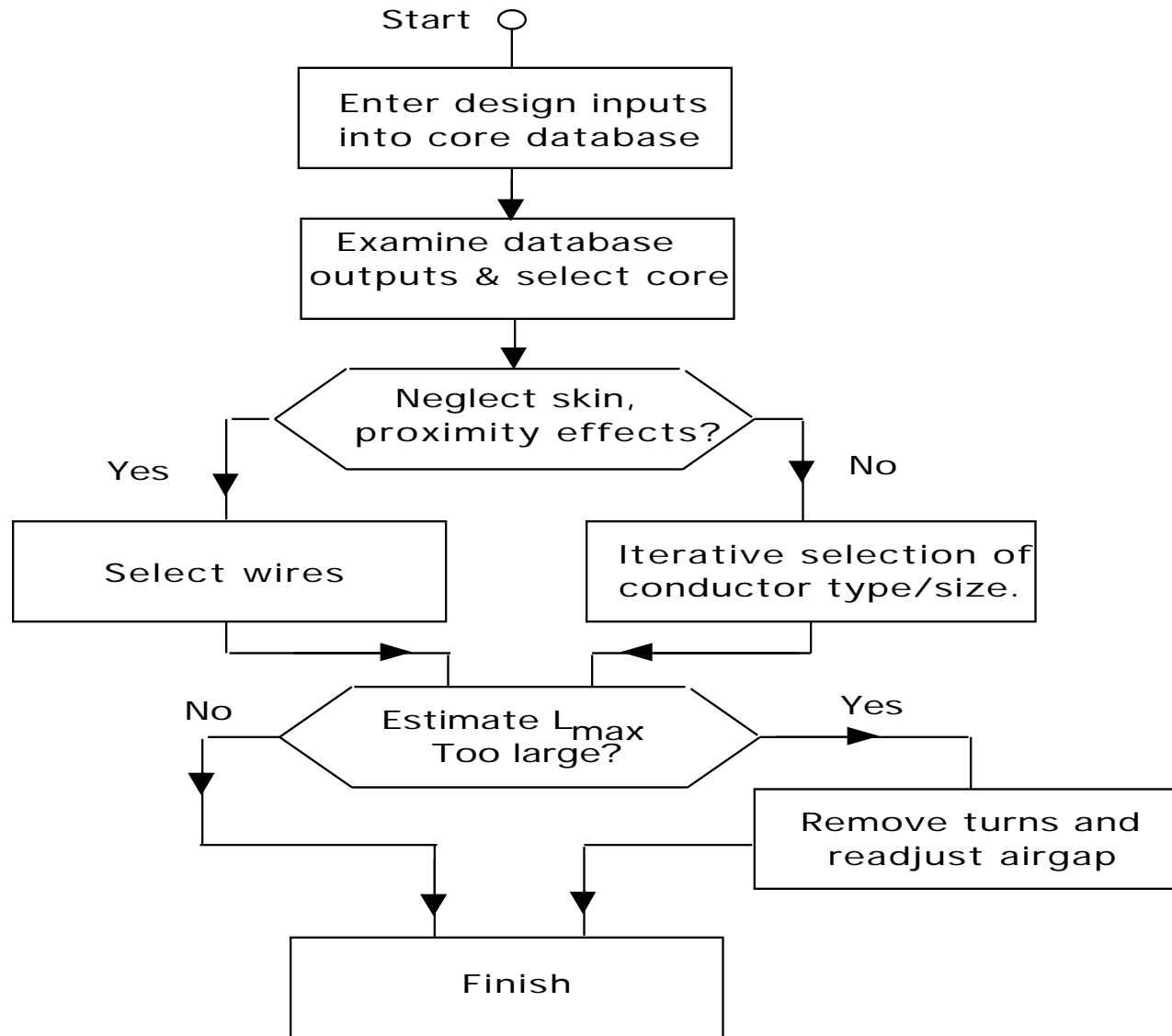

Inductor Design Example

- Assemble design inputs
 - $L = 300$ microhenries
 - Peak current = 5.6 A, sinewave current, $I_{\text{rms}} = 4$ A
 - Frequency = 100 kHz
 - $T_s = 100$ °C ; $T_a = 40$ °C
- Stored energy $L I_{\text{rms}}^2 = (3 \times 10^{-4})(5.6)(4) = 0.00068 \text{ J-m}^{-3}$
- Core material and geometric shape
 - High frequency operation dictates ferrite material. 3F3 material has highest performance factor PF at 100 kHz.
 - Double-E core chosen for core shape.
- Double-E core with $a = 1$ cm meets requirements.

$$k_{\text{cu}} J_{\text{rms}} \hat{B} A_w A_{\text{core}} = 0.0125 \sqrt{k_{\text{cu}}} 0.0068$$
 for $k_{\text{cu}} > 0.3$
- Database output: $R = 9.8$ °C/W and

$$P_{\text{sp}} = 237 \text{ mW/cm}^3$$

- Core flux density $B = 170$ mT from database. No I_{dc} , $B_{\text{peak}} = 170$ mT.
- Winding parameters.
 - Litz wire used, so $k_{\text{cu}} = 0.3$. $J_{\text{rms}} = 6 \text{ A/mm}^2$
 - $A_{\text{cu}} = (4 \text{ A}) / (6 \text{ A/mm}^2) = 0.67 \text{ mm}^2$
 - $N = (140 \text{ mm}^2) / ((0.3) / (0.67 \text{ mm}^2)) = 63$ turns.
- $L_{\text{max}} = \frac{(63)(170 \text{ mT})(1.5 \times 10^{-4} \text{ m}^2)}{5.6 \text{ A}} = 290$ microhenries
- $L_g = \frac{10^{-2}}{(0.17)(1.5 \times 10^{-4})} \frac{2.5 \times 10^{-2}}{(1.5 \times 10^{-2})(4 \times 10^{-7})(63)(5.6)} = \frac{2.5 \times 10^{-2}}{(4)(1.5 \times 10^{-2})} = 3 \text{ mm}$
- $L_{\text{max}} = L$ so no adjustment of inductance value is needed.

Iterative Inductor Design Procedure

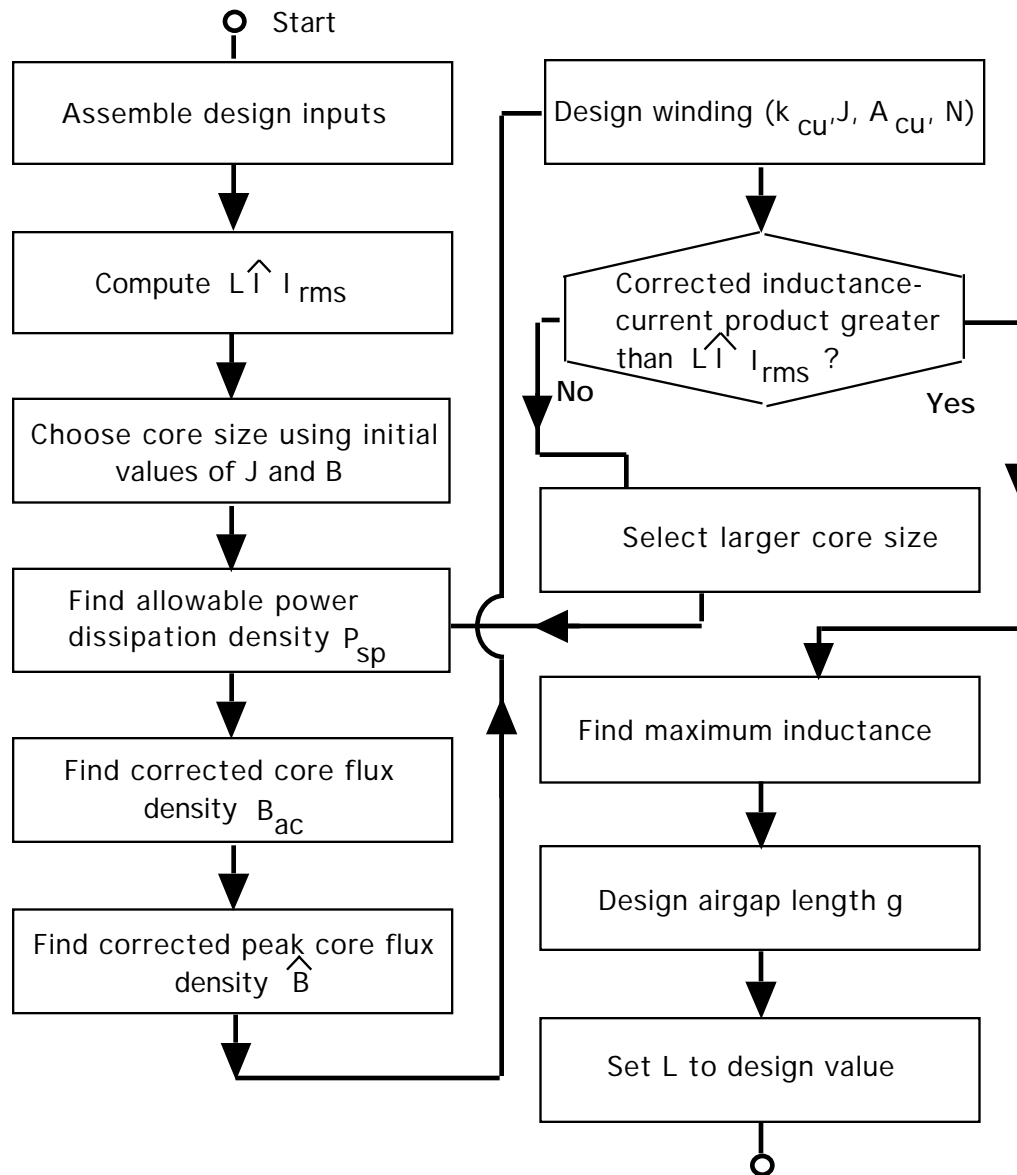

- Iterative design procedure essentially consists of constructing the core database until a suitable core is found.
- Choose core material and shape and conductor type as usual.
- Use stored energy relation to find an initial area product $A_w A_c$ and thus an initial core size.
 - Use initial values of $J_{rms} = 2-4 \text{ A/mm}^2$ and $B_{ac} = 50-100 \text{ mT}$.
- Use initial core size estimate (value of a in double-E core example) to find corrected values of J_{rms} and B_{ac} and thus corrected value of $k_{cu} J_{rms} \hat{B} A_w A_{core}$.
- Compare $k_{cu} J_{rms} \hat{B} A_w A_{core}$ with $\hat{L} I_{rms}$ and iterate as needed into proper size is found.

Simple, Non-optimal Inductor Design Method

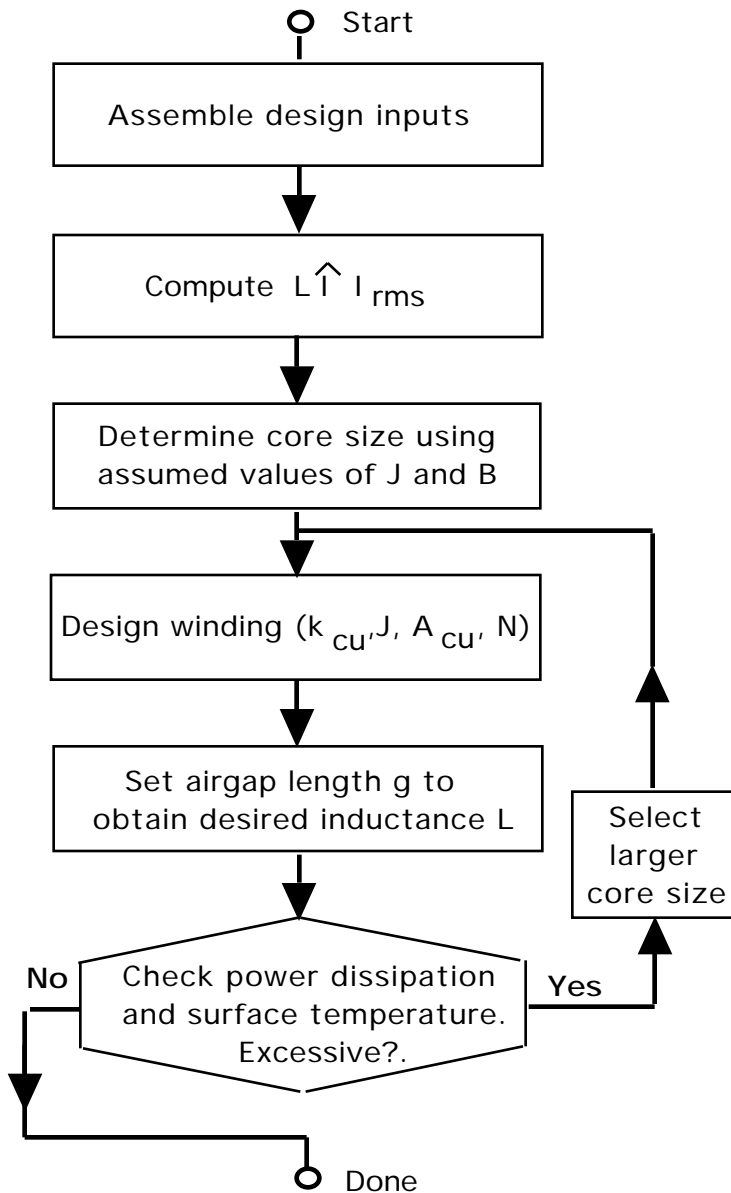

- Assemble design inputs and compute required LI_{rms}
- Choose core geometry and core material based on considerations discussed previously.
- Assume $J_{rms} = 2-4 \text{ A/mm}^2$ and $B_{ac} = 50-100 \text{ mT}$ and use $LI_{rms} = k_{cu} J_{rms} B_{ac} A_w A_{core}$ to find the required area product $A_w A_{core}$ and thus the core size.
 - Assumed values of J_{rms} and B_{ac} based on experience.
- Complete design of inductor as indicated.
- Check power dissipation and surface temperature using assumed values of J_{rms} and B_{ac} . If dissipation or temperature are excessive, select a larger core size and repeat design steps until dissipation/temperature are acceptable.
- Procedure is so-called area product method. Useful in situations where only one or two inductors are to be built and size/weight considerations are secondary to rapid construction and testing..

Analysis of Specific Transformer Design

- Transformer specifications
 - Wound on double-E core with $a = 1$ cm using 3F3 ferrite.
 - $I_{\text{pri}} = 4$ A rms, sinusoidal waveform;
 $V_{\text{pri}} = 300$ V rms.
 - Frequency = 100 kHz
 - Turns ratio $N_{\text{pri}}/N_{\text{sec}} = 4$ and $N_{\text{pri}} = 32$.
 - Winding window split evenly between primary and secondary and wound with Litz wire.
 - Transformer surface black ($E = 0.9$) and $T_a = 40$ °C.
- Find: core flux density, leakage inductance, and maximum surface temperature T_s , and effect of 25% overcurrent on T_s .
- Areas of primary and secondary conductors, $A_{\text{cu,pri}}$ and $A_{\text{cu,sec}}$
 - $A_{\text{w,pri}} = \frac{N_{\text{pri}} A_{\text{cu,pri}}}{k_{\text{cu,pri}}}$; $A_{\text{w,sec}} = \frac{N_{\text{sec}} A_{\text{cu,sec}}}{k_{\text{cu,sec}}}$
 - $A_{\text{w,pri}} + A_{\text{w,sec}} = A_{\text{w}} = \frac{N_{\text{pri}} A_{\text{cu,pri}}}{k_{\text{cu}}} + \frac{N_{\text{sec}} A_{\text{cu,sec}}}{k_{\text{cu}}}$
where $k_{\text{cu,pri}} = k_{\text{cu,sec}} = k_{\text{cu}}$ since we assume primary and secondary are wound with same type of conductor.
- Equal power dissipation density in primary and secondary gives
 - $$\frac{I_{\text{pri}}}{I_{\text{sec}}} = \frac{A_{\text{cu,pri}}}{A_{\text{cu,sec}}} = \frac{N_{\text{sec}}}{N_{\text{pri}}}$$
 - Using above equations yields $A_{\text{cu,pri}} = \frac{k_{\text{cu}} A_{\text{w}}}{2 N_{\text{pri}}}$ and $A_{\text{cu,sec}} = \frac{k_{\text{cu}} A_{\text{w}}}{2 N_{\text{sec}}}$
 - Numerical values: $A_{\text{cu,pri}} = \frac{(0.3)(140 \text{ mm}^2)}{(2)(32)} = 0.64 \text{ mm}^2$
and $A_{\text{cu,sec}} = \frac{(0.3)(140 \text{ mm}^2)}{(2)(8)} = 2.6 \text{ mm}^2$

Analysis of Specific Transformer Design (cont.)

- Power dissipation in winding $P_W = k_{cu} \rho_{cu} (J_{rms})^2 V_W$
- $J_{rms} = (4 \text{ A}) / (0.64 \text{ mm}^2) = (16 \text{ A}) / (2.6 \text{ mm}^2) = 6.2 \text{ A/mm}^2$
- $P_W = (0.3)(2.2 \times 10^{-8} \text{ ohm-m}) (6.2 \times 10^6 \text{ A/m}^2)^2 (1.23 \times 10^{-5} \text{ m}^3)$
 $P_W = 3.1 \text{ watts}$

- Flux density and core loss

- $V_{pri,max} = N_{pri} A_C \quad B_{ac} = (1.414)(300) = 425 \text{ V}$

- $B_{ac} = \frac{425}{(32)(1.5 \times 10^{-4} \text{ m}^2)(2)(10^5 \text{ Hz})} = 0.140 \text{ T}$

- $P_{core} = (13.5 \text{ cm}^3)(1.5 \times 10^{-6})(100 \text{ kHz})^{1.3}(140 \text{ mT})^{2.5} = 1.9 \text{ W}$

- Leakage inductance $L_{leak} = \frac{\mu_0 (N_{pri})^2 b_W l_W}{3 h_W}$
- $l_W = 8 a = 8 \text{ cm}$
- $L_{leak} = \frac{(4 \times 10^{-7})(32)^2(0.7)(10^{-2})(8 \times 10^{-2})}{(3)(2 \times 10^{-2})} = 12 \text{ microhenries}$

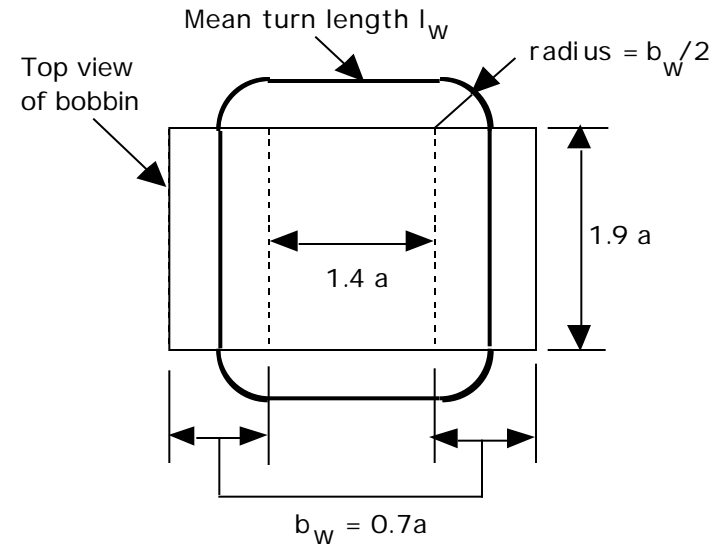

$$l_W = (2)(1.4a) + (2)(1.9a) + 2(0.35b_W) = 8 a$$

- Surface temperature T_S .
 - Assume $R_{\theta sa} = 9.8 \text{ }^\circ\text{C/W}$. Same geometry as inductor.
 - $T_S = (9.8)(3.1 + 1.9) + 40 = 89 \text{ }^\circ\text{C}$
- Effect of 25% overcurrent.
 - No change in core flux density. Constant voltage applied to primary keeps flux density constant.
 - $P_W = (3.1)(1.25)^2 = 4.8 \text{ watts}$
 - $T_S = (9.8)(4.8 + 1.9) + 40 = 106 \text{ }^\circ\text{C}$

Sectioning of Transformer Windings to Reduce Winding Losses

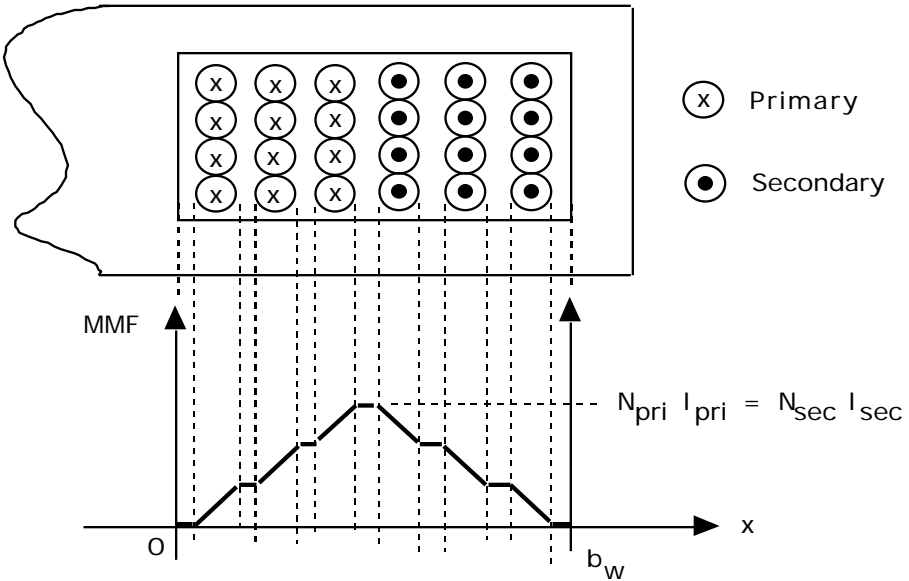

- Reduce winding losses by reducing magnetic field (or equivalently the mmf) seen by conductors in winding. Not possible in an inductor.
- Simple two-section transformer winding situation.

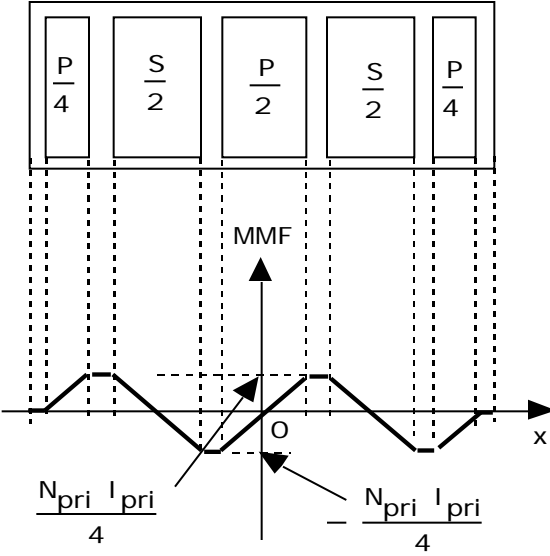
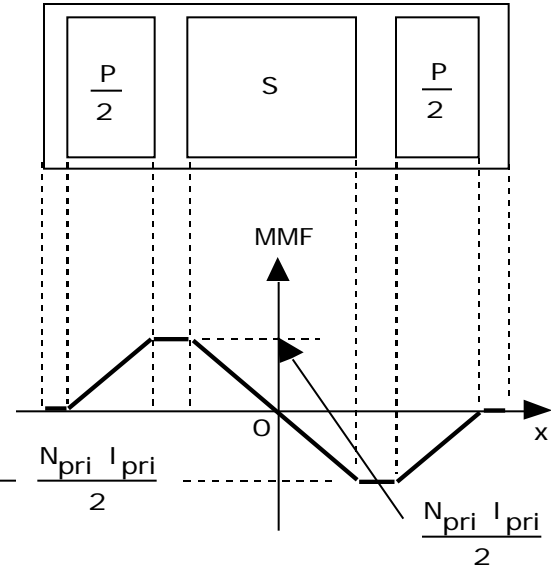

- Division into multiple sections reduces MMF and hence eddy current losses.

Optimization of Solid Conductor Windings

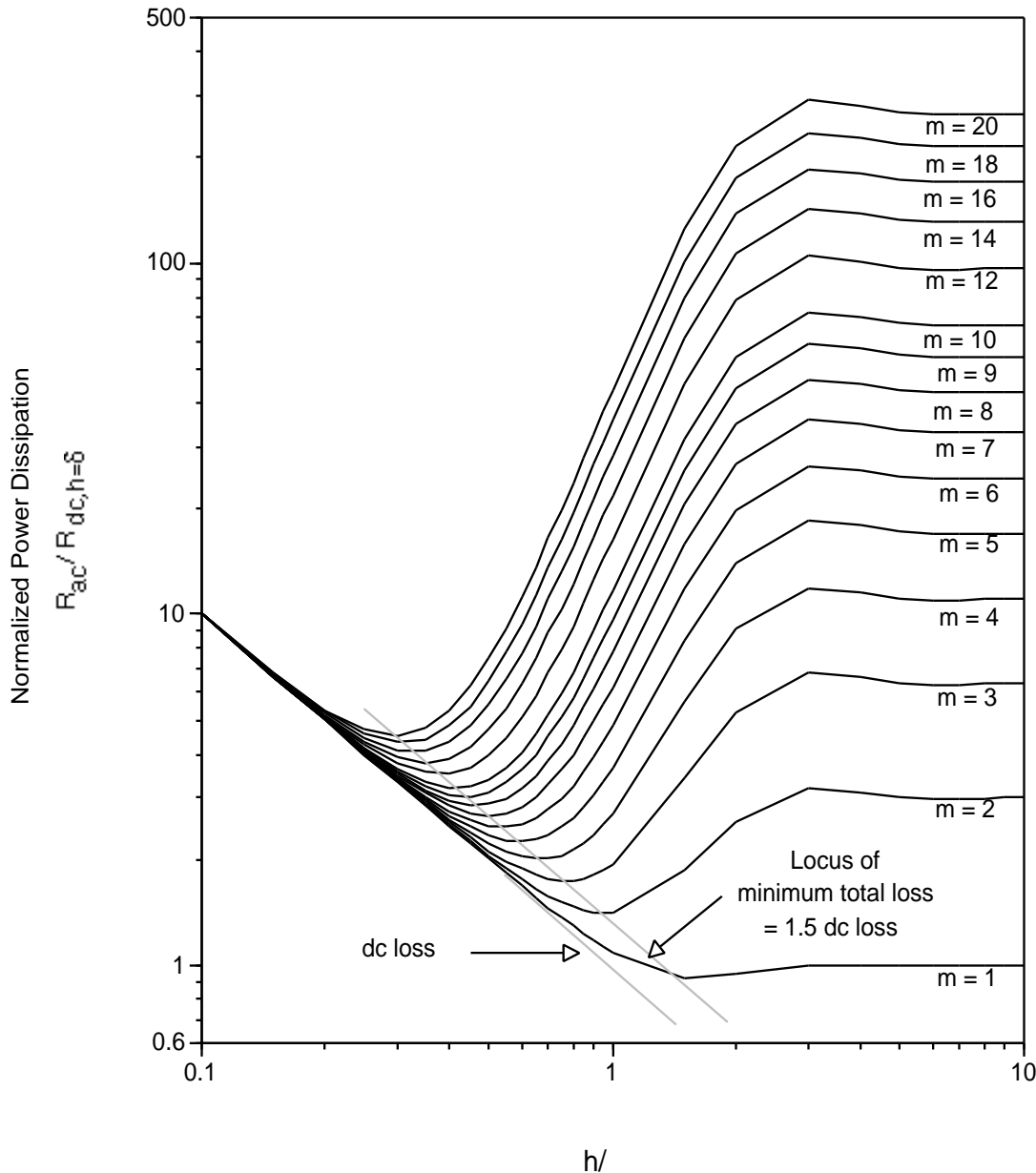

• Normalized power dissipation =

$$\frac{P_w}{R_{dc,h} (I_{rms})^2} = \frac{F_R R_{dc}}{R_{dc,h}}$$

• Conductor height/diameter $\frac{\sqrt{F_1} h}{d}$

• F_1 = copper layer factor

• $F_1 = b/b_o$ for rectangular conductors

• $F_1 = d/d_o$ for round conductors

• h = effective conductor height

• $h = \sqrt{\frac{4}{\pi}} d$ for round conductors

• m = number of layers

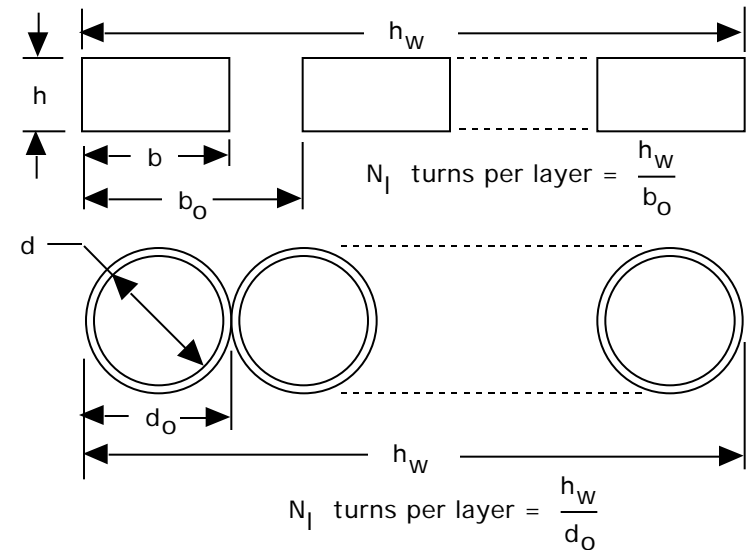

Transformer Leakage Inductance

- Transformer leakage inductance causes overvoltages across power switches at turn-off.
- Leakage inductance caused by magnetic flux which does not completely link primary and secondary windings.

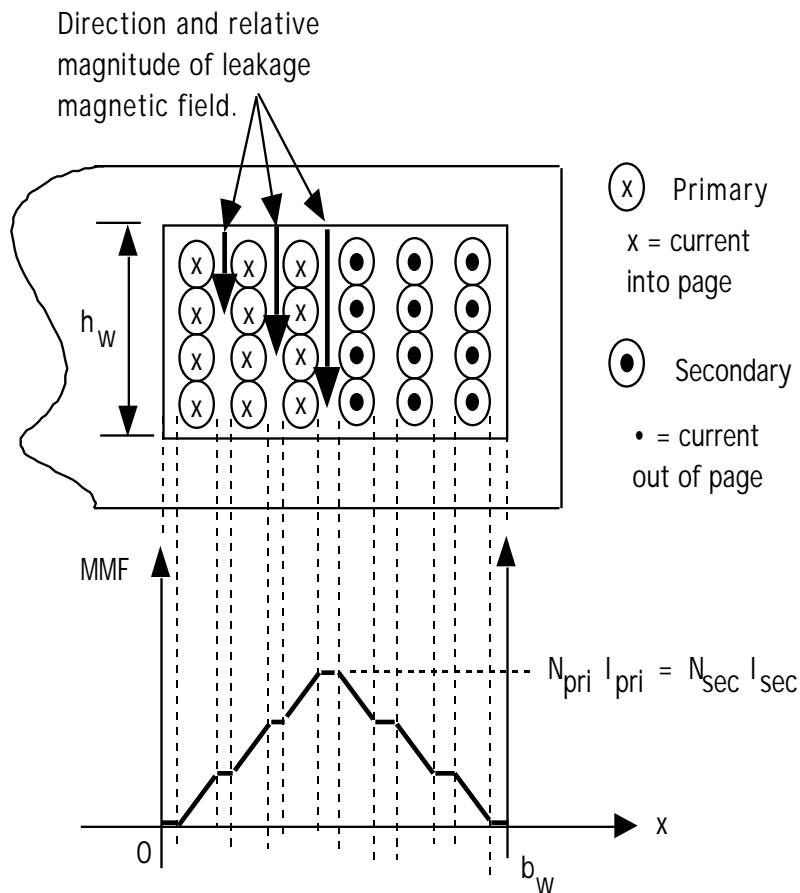

- Linear variation of mmf in winding window indicates spatial variation of magnetic flux in the window and thus incomplete flux linkage of primary and secondary windings.

$$H_{window} = H_{leak} = \frac{2 N_{pri} I_{pri} x}{h_w b_w} \quad ; \quad 0 < x < b_w/2$$

$$H_{leak} = \frac{2 N_{pri} I_{pri}}{h_w} (1 - x/b_w) \quad ; \quad b_w/2 < x < b_w$$

$$\frac{L_{leak} (I_{pri})^2}{2} = \frac{1}{2} \mu_0 (H_{leak})^2 dV$$

- Volume element $dV = h_w l_w(x) dx$; $l_w(x)$ equals the length of the conductor turn located at position x .
 - Assume a mean turn length $l_w \approx 8a$ for double-E core independent of x .

$$\frac{L_{leak} (I_{pri})^2}{2} = (2) \frac{1}{2} \mu_0 \left[\frac{2 N_{pri} I_{pri} x}{h_w b_w} \right]^2 h_w l_w dx$$

$$L_{leak} = \frac{\mu_0 (N_{pri})^2 l_w b_w}{3 p^2 h_w}$$

- If winding is split into $p+1$ sections, with $p > 1$, leakage inductance is greatly reduced.

Volt-Amp (Power) Rating - Basis of Transformer Design

- Input design specifications
 - Rated rms primary voltage V_{pri}
 - Rated rms primary current I_{pri}
 - Turns ratio N_{pri}/N_{sec}
 - Operating frequency f
 - Maximum temperatures T_s and T_a
- Design consists of the following:
 - Selection of core geometric shape and size
 - Core material
 - Winding conductor geometric shape and size
 - Number of turns in primary and secondary windings.
- Design procedure starting point - transformer V-A rating S
 - $S = V_{pri} I_{pri} + V_{sec} I_{sec} = 2 V_{pri} I_{pri}$
 - $V_{pri} = N_{pri} \frac{d}{dt} = \frac{N_{pri} A_{core} B_{ac}}{\sqrt{2}} ; I_{pri} = J_{rms} A_{cu,pri}$
 - $S = 2 V_{pri} I_{pri} = 2 \frac{N_{pri} A_{core} B_{ac}}{\sqrt{2}} J_{rms} A_{cu,pri}$
 - $A_{cu,pri} = \frac{k_{cu} A_w}{2 N_{pri}}$
 - $S = 2 V_{pri} I_{pri} = 2 \frac{N_{pri} A_{core} B_{ac}}{\sqrt{2}} J_{rms} \frac{k_{cu} A_w}{2 N_{pri}}$
 - $S = V_{pri} I_{pri} = 4.4 k_{cu} f A_{core} A_w J_{rms} B_{ac}$
- Equation relates input specifications (left-hand side) to core and winding parameters (right-hand side).
- Desired design procedure will consist of a systematic, single-pass method of selecting k_{cu} , A_{core} , A_w , J_{rms} , and B_{ac} .

Core Database - Basic Transformer Design Tool

- Interactive core database (spreadsheet-based) key to a single pass transformer design procedure.
 - User enters input specifications from converter design requirements. Type of conductor for windings (round wire, Leitz wire, or rectangular wire or foil) must be made so that copper fill factor k_{cu} is known.
 - Spreadsheet calculates capability of all cores in database and displays smallest size core of each type that meets V- I specification.
 - Also can be designed to calculate (and display as desired) design output parameters including J_{rms} , B , $A_{cu,pri}$, $A_{cu,sec}$, N_{pri} , N_{sec} , and leakage inductance..
 - Multiple iterations of core material and winding conductor choices can be quickly done to aid in selection of most appropriate tranformer design.
- Information on all core types, sizes, and materials must be stored on spreadsheet. Info includes dimensions, A_w , A_{core} , surface area of assembled transformer , and loss data for all materials of interest.
- Pre-stored information combined with user inputs to produce performance data for each core in spreadsheet. Sample of partial output shown below.

Core No.	Material	AP = $A_w A_c$	R T=60 °C	P _{sp} @ T _s =100 °C	J _{rms} @ T _s =100 °C & P _{sp}	\hat{B}_{rated} @ T _s =100 °C & 100 kHz	2.22 k _{cu} f J _{rms} \hat{B} AP (f = 100kHz)
• 8 •	• 3F3 •	• 2.1 cm ⁴ •	• 9.8 °C/W •	• 237 mW/cm ³ •	• (3.3/ $\sqrt{k_{cu}}$) • $\sqrt{\frac{R_{dc}}{R_{ac}}}$ • A/mm ² •	• 170 mT •	• 2.6x10 ³ • $\sqrt{\frac{k_{cu} R_{dc}}{R_{ac}}}$ • [V-A] •

Details of Interactive Transformer Core Database Calculations

- User inputs: V_{pri} , I_{pri} , turns ratio N_{dc}/N_{sec} , f , T_s , T_a , and k_{cu}
- Stored information (static, independent of converter requirements)
 - Core dimensions, A_w , A_{core} , V_c , V_w , surface area, mean turn length, mean magnetic path length, etc.
 - Quantitative core loss formulas for all materials of interest including approximate temperature dependence.
- Calculation of core capabilities
 1. Compute converter-required stored energy value: $S = 2 V_{pri} I_{pri}$
 2. Compute allowable specific power dissipation $P_{sp} = [T_s - T_a] / \{ R_{sa} [V_c + V_w] \}$. $R_{sa} = h/A_s$ or calculated interactively using input temperatures and formulas for convective and radiative heat transfer from Heat Sink chapter.
 3. Compute allowable flux density $P_{sp} = k f^b [B_{ac}]^d$ and current density $P_{sp} = k_{cu} J_{rms}^2$.
 4. Compute core capabilities $4.4 f k_{cu} A_w A_{core} B_{ac} J_{rms}$
- Calculation transformer parameters.
 1. Calculate number of primary turns $N_{pri} = V_{pri} / \{ 2 f A_{cpre} B_{ac} \}$ and secondary turns $N_{sec} = V_{sec} / \{ 2 f A_{cpre} B_{ac} \}$
 2. Calculate winding conductor areas assuming low frequencies or use of Leitz wire
 - $A_{cu,pri} = [k_{cu} A_w] / [2 N_{pri}]$ and $A_{cu,sec} = [k_{cu} A_w] / [2 N_{sec}]$

Details of Interactive Transformer Core Database Calculations (cont.)

3. Calculate winding areas assuming eddy current/proximity effect is important

- Only solid conductors, round wires or rectangular wires (foils), used. $J_{\text{rms}} = [\{P_{\text{sp}} R_{\text{dc}}\} / \{R_{\text{ac}} k_{\text{cu}} r_{\text{cu}}\}]^{1/2}$
- Conductor dimensions must simultaneously satisfy area requirements and requirements of normalized power dissipation versus normalized conductor dimensions.
- May require change in choice of conductor shape. Most likely will require choice of foils (rectangular shapes).
- Several iterations may be needed to find proper combinations of dimensions, number of turns per layer, and number of layers and sections.
- Best illustrated by a specific design example.

4. Estimate leakage inductance $L_{\text{leak}} = \{\mu_o \{N_{\text{pri}}\}^2 l_w b_w\} / \{3 p^2 h_w\}$

5. Estimate $S_{\text{max}} = 4.4 k_{\text{cu}} f A_{\text{core}} A_w J_{\text{rms}} B_{\text{ac}}$

6. If $S_{\text{max}} > S = 2 V_{\text{pri}} I_{\text{pri}}$ reduce S_{max} and save on copper cost, weight, and volume.

- If $N_{\text{pri}} w A_c B_{\text{ac}} > V_{\text{pri}}$, reduce S_{max} by reducing N_{pri} and N_{sec} .
- If $J_{\text{rms}} A_{\text{cu, pri}} > I_{\text{rms}}$, reduce $A_{\text{cu, pri}}$ and $A_{\text{cu, sec}}$.
- If $S > S_{\text{max}}$ by only a moderate amount (10-20%) and smaller than S_{max} of next core size, increase S_{max} of present core size.
- Increase I_{rms} (and thus winding power dissipation) as needed. Temperature T_s will increase a modest amount above design limit, but may be preferable to going to larger core size.

Single Pass Transformer Design Procedure

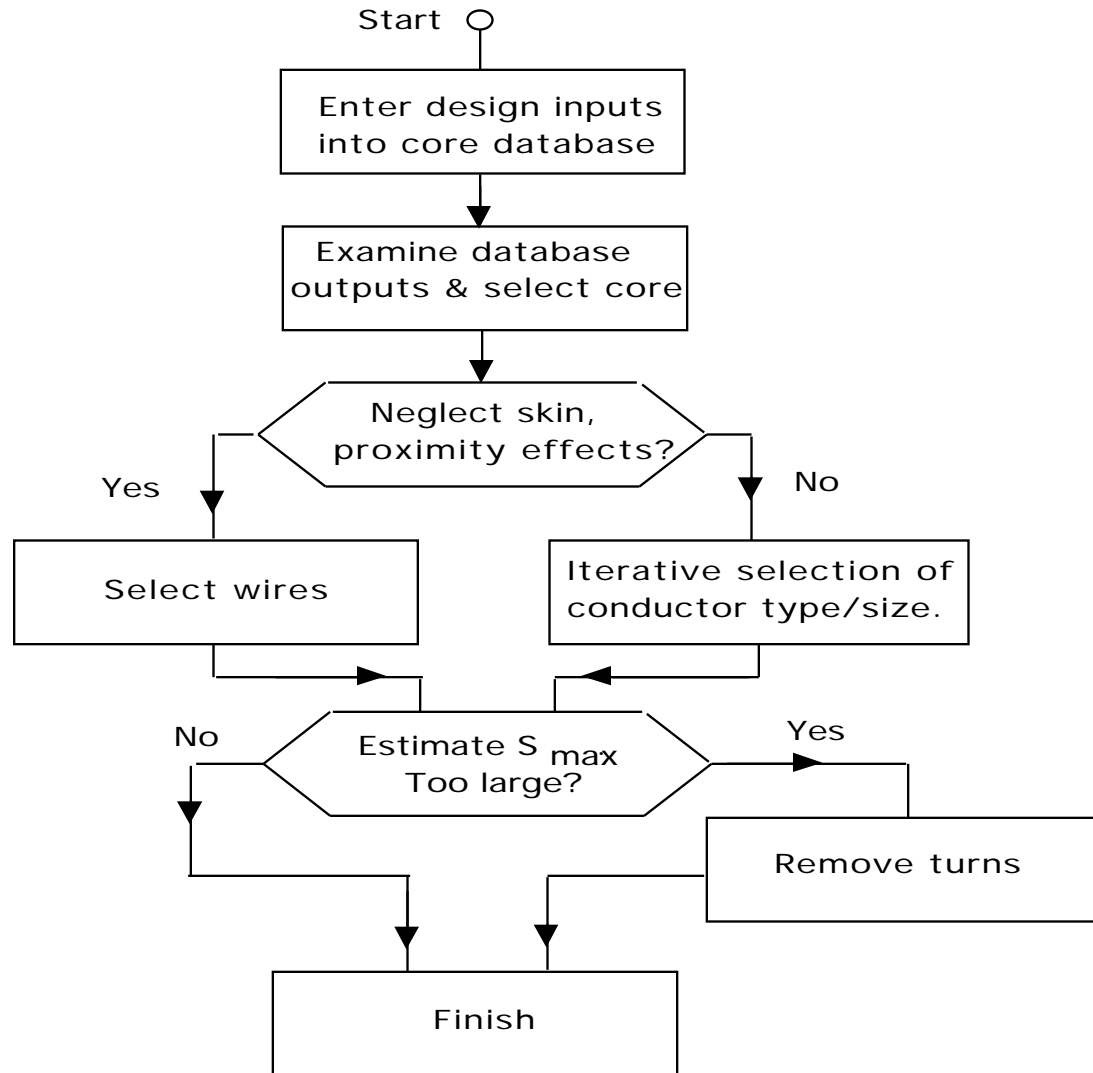

Transformer Design Example

- Design inputs
 - $V_{\text{pri}} = 300 \text{ V rms}$; $I_{\text{rms}} = 4 \text{ A rms}$
 - Turns ratio $n = 4$
 - Operating frequency $f = 100 \text{ kHz}$
 - $T_s = 100 \text{ }^\circ\text{C}$ and $T_a = 40 \text{ }^\circ\text{C}$

- V - I rating $S = (300 \text{ V rms})(4 \text{ A rms})$
 $= 1200 \text{ watts}$

- Core material, shape, and size.
 - Use 3F3 ferrite because it has largest performance factor at 100 kHz.
 - Use double-E core. Relatively easy to fabricate winding.

- Core volt-amp rating $= 2,600 \sqrt{k_{\text{cu}}} \sqrt{\frac{R_{\text{dc}}}{R_{\text{ac}}}}$
 - Use solid rectangular conductor for windings because of high frequency. Thus $k_{\text{cu}} = 0.6$ and $R_{\text{ac}}/R_{\text{dc}} = 1.5$.
 - Core volt-amp capability $= 2,600 \sqrt{\frac{0.6}{1.5}}$
 $= 1644 \text{ watts}$. $> 1200 \text{ watt transformer rating}$.
 Size is adequate.

- Using core database, $R_c = 9.8 \text{ }^\circ\text{C/W}$
 and $P_{\text{sp}} = 240 \text{ mW/cm}^3$.

- Flux density and number of primary and secondary turns.
 - From core database, $B_{\text{ac}} = 170 \text{ mT}$.
 - $N_{\text{pri}} = \frac{300 \sqrt{2}}{(1.5 \times 10^{-4} \text{ m}^2)(2)(10^5 \text{ Hz})(0.17 \text{ T})}$
 $= 26.5$ 24. Rounded down to 24 to increase flexibility in designing sectionalized transformer winding.
 - $N_{\text{sec}} = \frac{24}{6} = 6$.

- From core database $J_{\text{rms}} = \frac{3.3}{\sqrt{(0.6)(1.5)}}$
 $= 3.5 \text{ A/mm}^2$.
 - $A_{\text{cu,pri}} = \frac{4 \text{ A rms}}{3.5 \text{ A rms/mm}^2} = 1.15 \text{ mm}^2$
 - $A_{\text{cu,sec}} = (4)(1.15 \text{ mm}^2) = 4.6 \text{ mm}^2$

Transformer Design Example (cont.)

- Primary and secondary conductor areas - proximity effect/eddy currents included. Assume rectangular (foil) conductors with $k_{cu} = 0.6$ and layer factor $F_1 = 0.9$.

- Iterate to find compatible foil thicknesses and number of winding sections.
- 1st iteration - assume a single primary section and a single secondary section and each section having single turn per layer. Primary has 24 layers and secondary has 6 layers.

- Primary layer height $h_{pri} = \frac{A_{cu,pri}}{F_1 h_w}$

$$= \frac{1.15 \text{ mm}^2}{(0.9)(20 \text{ mm})} = 0.064 \text{ mm}$$

- Normalized primary conductor height

$$= \frac{\sqrt{F_1} h_{pri}}{d} = \frac{\sqrt{0.9} (0.064 \text{ mm})}{(0.24 \text{ mm})} = 0.25 ;$$

$$= 0.24 \text{ mm in copper at } 100 \text{ kHz and } 100 \text{ }^\circ\text{C}.$$

- Optimum normalized primary conductor height = 0.3 so primary winding design is satisfactory.

- Secondary layer height $h_{sec} = \frac{A_{cu,sec}}{F_1 h_w}$

$$= \frac{4.6 \text{ mm}^2}{(0.9)(20 \text{ mm})} = 0.26 \text{ mm}.$$

- Normalized secondary conductor height

$$= \frac{\sqrt{F_1} h_{sec}}{d} = \frac{\sqrt{0.9} (0.26 \text{ mm})}{(0.24 \text{ mm})} = 1$$

- However a six layer section has an optimum = 0.6. A two layer section has an optimum = 1. 2nd iteration needed.

- 2nd iteration - sectionalize the windings.

- Use a secondary of 3 sections, each having two layers, of height $h_{sec} = 0.26 \text{ mm}$.
- Secondary must have single turn per layer. Two turns per layer would require $h_{sec} = 0.52 \text{ mm}$ and thus = 2. Examination of normalized power dissipation curves shows no optimum = 2.

Transformer Design Example (cont.)

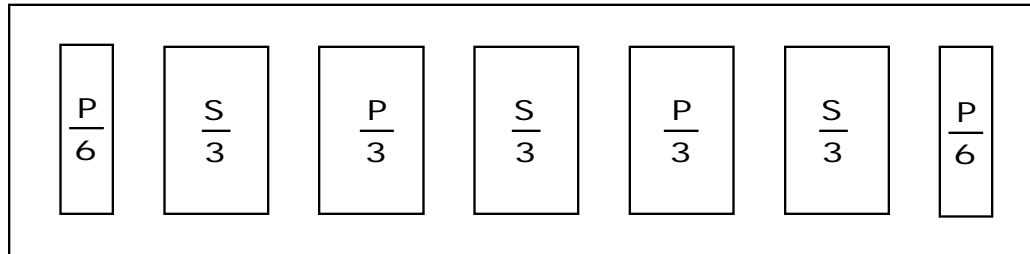

- Three secondary sections requires four primary sections.
 - Two outer primary sections would have $24/6 = 4$ turns each and the inner two sections would have $24/3 = 8$ turns each.
 - Need to determine number of turns per layer and hence number of layers per section.

Turns/ layer	h_{pri}	No. of Layers		Optimum
1	0.064 mm	8	0.25	0.45
2	0.128 mm	4	0.5	0.6
4	0.26 mm	2	1	1

- Use four turns per layer. Two interior primary sections have two layers and optimum value of . Two outer sections have one layer each and not optimum, but only results in slight increase in loss above the minimum.

- Leakage inductance L_{leak}

$$= \frac{(4 \times 10^{-9})(24)^2(8)(0.7)(1)}{(3)(6)^2(2)} = 0.2 \mu\text{H}$$

- Sectionalizing increases capacitance between windings and thus lowers the transformer self-resonant frequency.
- $S_{max} = 1644$ watts
- Rated value of $S = 1200$ watts only marginally smaller than S_{max} . Little to be gained in reducing S_{max} to S unless a large number of transformer of this design are to be fabricated.

Iterative Transformer Design Procedure

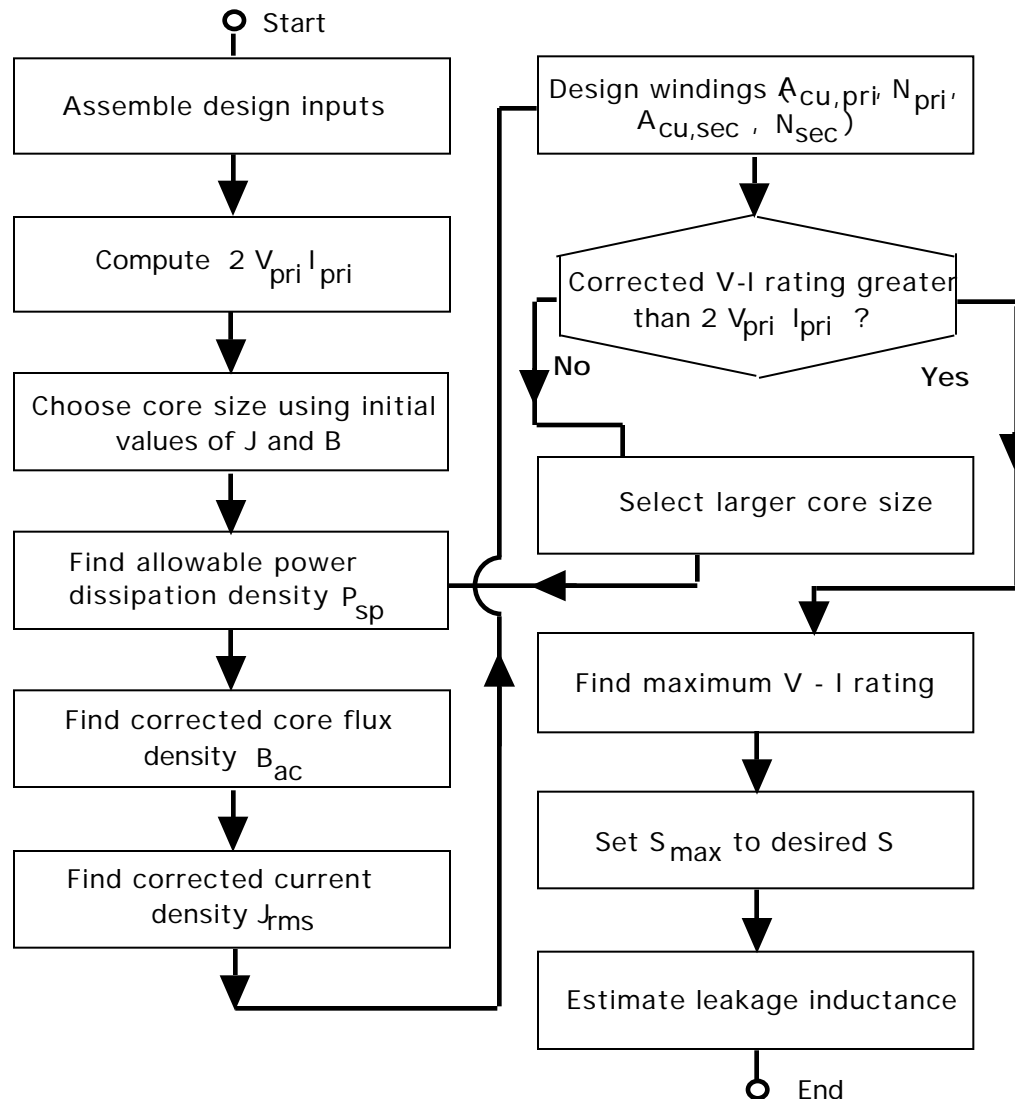

- Iterative design procedure essentially consists of constructing the core database until a suitable core is found.
- Choose core material and shape and conductor type as usual.
- Use V - I rating to find an initial area product $A_w A_c$ and thus an initial core size.
 - Use initial values of $J_{rms} = 2-4 \text{ A/mm}^2$ and $B_{ac} = 50-100 \text{ mT}$.
- Use initial core size estimate (value of a in double-E core example) to find corrected values of J_{rms} and B_{ac} and thus corrected value of $4.4 f k_{cu} J_{rms} \hat{B} A_w A_{core}$.
- Compare $4.4 f k_{cu} J_{rms} \hat{B} A_w A_{core}$ with $2 V_{pri} I_{pri}$ and iterate as needed into proper size is found.

Simple, Non-optimal Transformer Design Method

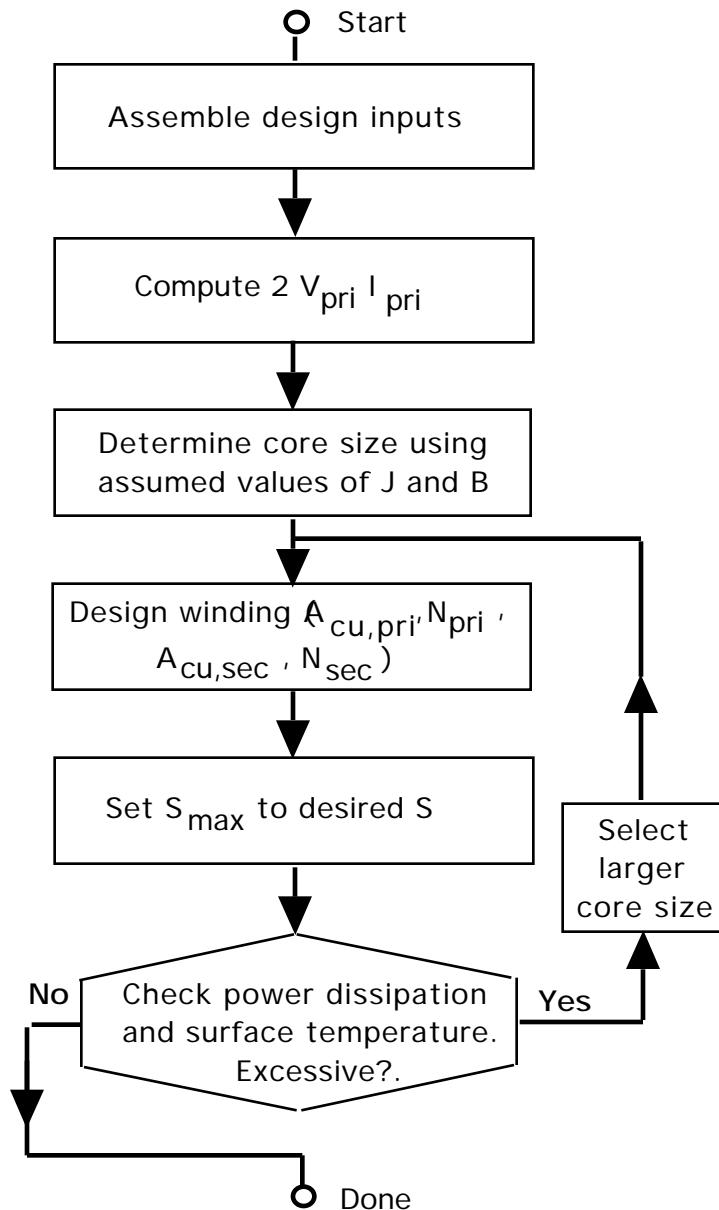

- Assemble design inputs and compute required $2 V_{pri} I_{pri}$
- Choose core geometry and core material based on considerations discussed previously.
- Assume $J_{rms} = 2-4 \text{ A/mm}^2$ and $B_{ac} = 50-100 \text{ mT}$ and use $2 V_{pri} I_{pri} = 4.4 f k_{cu} J_{rms} B_{ac} A_w A_{core}$ to find the required area product $A_w A_{core}$ and thus the core size.
 - Assumed values of J_{rms} and B_{ac} based on experience.
- Complete design of transformer as indicated.
- Check power dissipation and surface temperature using assumed values of J_{rms} and B_{ac} . If dissipation or temperature are excessive, select a larger core size and repeat design steps until dissipation/temperature are acceptable.
- Procedure is so-called area product method. Useful in situations where only one or two transformers are to be built and size/weight considerations are secondary to rapid construction and testing..